

Mariana Islands

# **HOMEOWNER'S HANDBOOK TO PREPARE FOR NATURAL HAZARDS**



May 2015  
Published by the University of Guam  
Sea Grant Program  
First Edition, Version 1.1



May 2015  
Published by the University of Guam  
Sea Grant Program  
First Edition, Version 1.1

# Mariana Islands

# **HOMEOWNER'S HANDBOOK TO PREPARE FOR NATURAL HAZARDS**

Laura A. F. Biggs, UOG Sea Grant  
Erin Derrington, CNMI Coastal Resources Management  
Dennis Hwang, UH Sea Grant  
Darren Okimoto, UH Sea Grant  
Jesse P. Bamba, UOG CE&O  
Phoebe Wall, UOG CE&O  
Roland Quitugua, UOG CE&O

## ACKNOWLEDGEMENTS

National Weather Service - Forecast Office Guam; Charles Guard, Guam Building Code Council; Brent Wiese, Guam Homeland Security; Gabriel Jugo, University of Hawai'i Sea Grant College Program; CNMI Coastal Resources Management; NOAA Coastal Storms Program Grant

This book was published with funds from the Coastal Storms Program and in collaboration (Grant NOAA09OAR4170060-MA130020). Thank you to Dennis Hwang for sharing the content and allowing UOGSG to adapt for the Marianas and Cindy Knapman and UHSG communications staff for providing the layout template. Content from the 1976 UOG Extension Service Publication 'Typhoon Tips 2nd Edition' was updated and modified for inclusion in this handbook. In addition, financial assistance was provided by the Coastal Zone Management Act of 1972, as amended, administered by the Office of Ocean and Coastal Resource Management, National Oceanic and Atmospheric Administration.

Disclaimer: This information is for educational purposes only and is subject to change. It is the responsibility of those considering taking this advice to be knowledgeable about any updates and to take responsibility for their safety.

Editorial responsibility for this book rests with the lead author.

# CONTENTS

## **BE INFORMED ..... READING MATERIAL**

Threats Affecting the Mariana Islands.....	2
Earthquakes .....	4
Tsunamis.....	6
Flooding .....	14
Typhoons .....	15
Climate Change .....	18
Volcanoes .....	22
Emergency Systems, Sirens and Responding Agencies .....	23

## **MAKE A PLAN BUILD A KIT ..... READING MATERIAL**

Ten Simple Steps to Start .....	25
Make a Family Emergency Plan .....	26
Build a Kit.....	26
Make Evacuation Plans.....	27
Prepare Your Home for an Earthquake.....	31
Making Your Home Flood Ready .....	32
Evaluate Your Home and Property .....	35
Preparing a Wood or Tin Structure for Typhoons .....	36
Typhoon Shutters and Window Coverings.....	46
Installing Plywood Shutters .....	51
Overview of Wind Resistive Devices.....	57
Protection with Insurance.....	63

## **PREPARING FOR A HAZARD..... FOUR DAYS BEFORE**

Emergency Kit, Food and Water .....	75
Emergency Contact Information.....	76
COR 3 & 2 Emergency Checklist (Home, Yard, Vehicles).....	78
COR 1 Emergency Checklist .....	80
Going to a Shelter .....	82
Preparing Your Home .....	83
Medical Needs .....	83

Securing Boats.....	84
Prepare for Flooding .....	85
Securing Gardens and Farms .....	85
Getting Generators Ready .....	86
How to React During Flooding .....	87

**IF SOMEONE IS INJURED.....IMMEDIATE ATTENTION**

Go to a Doctor if.....	89
How to Care for Minor Wounds.....	91

**HEADING HOME ..... AFTER THE ALL CLEAR IS GIVEN**

Getting Home .....	93
Hazard Recovery Checklist.....	94
Drinking Water Safety .....	96
Water for Other Uses .....	97
Food Safety.....	99
Stopping the Spread of Disease and Invasive Species .....	102
Cleaning the Ranch.....	105
Special Considerations for Flooding .....	107
Potential Hazardous Materials .....	109
Care of Soiled Clothing and Textiles.....	110
Helping Children Cope with a Disaster .....	113

**CHECKLISTS AND VISUAL TOOLS ..... Reference Guide**

Family Emergency Plan .....	119
Important Contact Information.....	120
Shelter Information.....	122
Emergency Kit Checklist .....	123
COR 3 & 2 Preparation Checklist (Home, Yard, Vehicles).....	124
COR1 Preparation Checklist .....	126
Hazard Recovery Checklist.....	127
Food & Water Safety Checklist .....	128
Potential Hazardous Materials .....	129
Notes.....	130

# BE INFORMED

## READING MATERIAL

Threats Affecting the Mariana Islands.....	2
Earthquakes .....	4
Tsunamis.....	6
Flooding .....	14
Typhoons .....	15
Climate Change Impacts.....	18
Volcanos .....	22
Emergency Systems, Sirens and Responding Agencies .....	23

You can take action to significantly lower your risk of damage from natural hazards. Natural hazards present numerous risks to residents and homeowners. While it may be difficult to prevent all damage, remaining informed, planning, and responding accordingly can reduce your risks and save lives.

You may be one of the many homeowners who have not fully prepared for a natural hazard. Now is the time to prepare. It is not a matter of IF the next typhoon, earthquake or tsunami will occur, but WHEN.

Storms have been minimal over the past decade. There is a good chance you will experience a major typhoon or

other natural disaster in your lifetime. Typhoons Faxai, Neoguri and Halong all passed near The Marianas in 2014. They serve as an important reminder that the Mariana Islands are vulnerable to typhoons and tropical storms.

The Marianas has documented tsunamis in historical records. Since 1975, we have not had a damaging tsunami until the recent tsunamis associated with the Chile earthquake in 2010 and the Japan earthquake in 2011.

Climate change impacts will affect our islands, ensuring that we are well informed and prepared for all natural hazards will ensure resiliency.

# THREATS AFFECTING THE MARIANAS

## Earthquake

- Typically residents feel earthquakes before they are told about them.
- Earthquake information is provided by the U.S. Geological Survey office. Their web site is: [geomag.usgs.gov/observatories/guam/](http://geomag.usgs.gov/observatories/guam/)

## Tsunami

- Tsunamis typically follow an underwater earthquake. If you feel a strong earthquake that lasts longer than 20 seconds, move 50 feet up and 100 feet inland (even without sirens).
- Guam is equipped with tsunami warning system. If you hear the sirens, or your mayor's warning, move to higher ground immediately.

## Flooding

- Flood warnings are issued on TV, radio, social media and newspapers.
- If you see large amounts of rain in a short time period, be prepared for flooding. If you hiking and it is raining upstream, a flash flood is imminent.
- Landslides can occur with significant rainfall. If there is a flooding advisory or warning for your village, be prepared for a landslide if you live near steep slopes.

## Typhoon

- Residents of the Marianas typically have time to prepare for typhoons.
- The storm will be predicted by the NOAA National Weather Service.
- Announcements will typically be made on local radio, TV, newspapers and online.

## Climate Change

- Changing weather patterns, sea level rise, and severity of storms will occur in the region as a result of climate change.

## Volcanoes (CNMI)

- Active volcanoes are present in the Northern Marianas.
- The U.S. Geological Survey provides information about the status of volcanoes in the CNMI.



Figure 1.1. Damage to the Royal Palm Resort Guam, a new 12-story hotel and condominium complex, after an 8.1 earthquake on Aug. 8, 1993. The building collapsed just 18 days after opening. Source: FEMA.

## The Mariana Islands Are Resilient



The communities of the Mariana Islands have had many experiences that help us better respond to the threats that effect our region. This experience has been acknowledged through federal programs (National Weather Service); Guam, Saipan, Tinian, and Rota are recognized as StormReady and TsunamiReady communities.

Use the information from this handbook, the National Weather Service, and the Office of Civil Defense to make informed decisions about how you respond to threats. This will ensure that our communities continue to be READY.

### **Guam, Rota, Tinian, and Saipan are Storm and Tsunami Ready because they:**

- Established a 24-hour warning point and emergency operations center
- Created a system that monitors local weather and ocean conditions
- Developed multiple ways to receive tsunami and severe weather warnings, and alert the public in a timely manner
- Developed a formal hazard plan and conduct emergency exercises
- Promoted public readiness through community education



# EARTHQUAKES

From Farallon de Pajaros to Guam, the Mariana Islands are located in an active tectonic zone where the Pacific Plate is sliding below the Philippine Plate, a process known as 'subduction'. This geological process gave birth to this island chain, but it also makes this region susceptible to earthquakes, as well as volcanic activity in the northern islands of Agrigan, Alamagan, Anatahan, Asuncion, Farrallon de Parjaros, Gugan, Maug, Pagan, and Sarigan. Guam is located only 30 kilometers west of the Mariana Trench, the location of active 'subduction'. This movement of tectonic plates is the cause of many earthquakes in the Mariana Islands.

The Richter scale gives a number to the amount of energy released when an earthquake happens. An earthquake that is less than 3.9 is considered minor and rarely causes damage. Quakes below 5.9 are considered moderate and those above 7.0 are major.

While earthquakes can occur at any time, in the CNMI 23 earthquakes registering 7 or more on the Richter scale have been recorded since 1900. No serious damage has occurred in recent recorded history. Earthquakes with a magnitude of 4 or 5 on the Richter scale can be felt by people and occur once or twice a year.

There are weekly tremors which cannot be observed without instruments. The epicenters of most earthquakes are located on the Pacific Ocean floor and intensities generally diminish before reaching the Marianas. Reportedly, a small section of the Trench near Rota has a shallow subduction plate – a formation that can produce earthquakes that trigger tsunamis for the Mariana Islands.

## Major Mariana Earthquakes

August 8, 1993 - 8.1 magnitude

April 26, 2002 - 7.1 magnitude

May 9, 2008 - 6.8 magnitude

No significant damage or injuries were reported in CNMI from these events. Of those quakes on Guam 48 people were injured. Damage to the port and to hotels were reported; landslides also occurred.

**Earthquakes can cause tsunamis.**

**The National Disaster Preparedness Training Center (NDPTC) recommends that if you feel an earthquake that lasts longer than 20 seconds and/or prevents you from standing up you should duck, cover, hold on, then seek higher ground immediately. Tsunami waves can be generated locally and will reach the island within minutes. See Table 1.2 on page 12 for information.**

## MYTH: Guam & CNMI Are Not Susceptible To Tsunamis

Guam and CNMI are in fact susceptible to earthquakes and the tsunamis that are generated from them. Many people believe that Guam and CNMI are protected from destructive tsunamis. Many factors lead to this belief including that: Guam and CNMI have not had a significant tsunami in recent history; the thought that offshore reefs and significant ocean depth offshore may help break the force of tsunami waves; that the Mariana Trench is far enough away that it will not present danger from subducting tectonic plates; and that the Mariana Trench will suck the energy from an approaching tsunami.

American Samoa shares nearly exact physical and historical characteristics with Guam and CNMI. A devastating tsunami struck in September 2009 that was generated from a 8.1 earthquake in the Tonga Trench. The tsunami significantly damaged infrastructure in Pago Pago, American Samoa and killed over 191 people in American Samoa, Samoa, and Tonga combined.

Learning from the past will help us remain resilient and prepared for future hazards. Heed the tips in Tables 1.1 and 1.2 when responding to earthquakes and tsunamis.

### Action to Take After a Strong Earthquake

- A tsunami from a local earthquake could strike before a tsunami warning can be announced.
- DO NOT WAIT for a tsunami warning to be announced.
- If you are at the beach or near the ocean and you feel the earth shake strongly or for a long time, move immediately to higher ground.
- Stay away from rivers and streams that lead to the ocean if there is a tsunami.
- Tsunamis generated in distant locations will generally give people enough time to move to higher ground.
- High, concrete hotels in Tumon, can provide a safe place on the upper floors.
- Homes and small buildings located in low-lying coastal areas are not designed to withstand tsunami impacts. Don't stay in these structures should there be a tsunami warning.

# TSUNAMIS

A tsunami is a set of ocean waves caused by any large, abrupt disturbance of the ocean's surface. Even if the disturbance is small, if it is close to the coastline, a tsunami can demolish coastal communities within minutes. A very large disturbance can cause local devastation and export tsunami destruction thousands of miles away. The word tsunami is a Japanese word, represented by two characters: tsu, meaning, "harbor", and nami meaning, "wave". There are three types of tsunamis, local, regional, and distant. Since 1850, tsunamis have been

responsible for the loss of over 420,000 lives and billions of dollars of damage around the world.

## How a Tsunami Forms

Tsunamis are most commonly generated by earthquakes in the ocean or coastal areas. Major tsunamis are produced by large (greater than 7 on the Richter scale), shallow focus (< 70 miles depth in the earth) earthquakes. They frequently occur in the Pacific, where tectonic plates fracture and provide a vertical displacement of the sea floor. Imagine the lip of a

subducting plate quickly snapping up and 'punching' a huge column of ocean water to the surface, see Figure 1.3 on page eight.

## Are the Marianas at Risk for Tsunamis?

Since 1849 Guam has had three tsunamis causing damage at more than one location. Tsunami waves hit Guam in 1849, 1892 and 1993 according to *The Tsunami History of Guam: 1849-1993*.

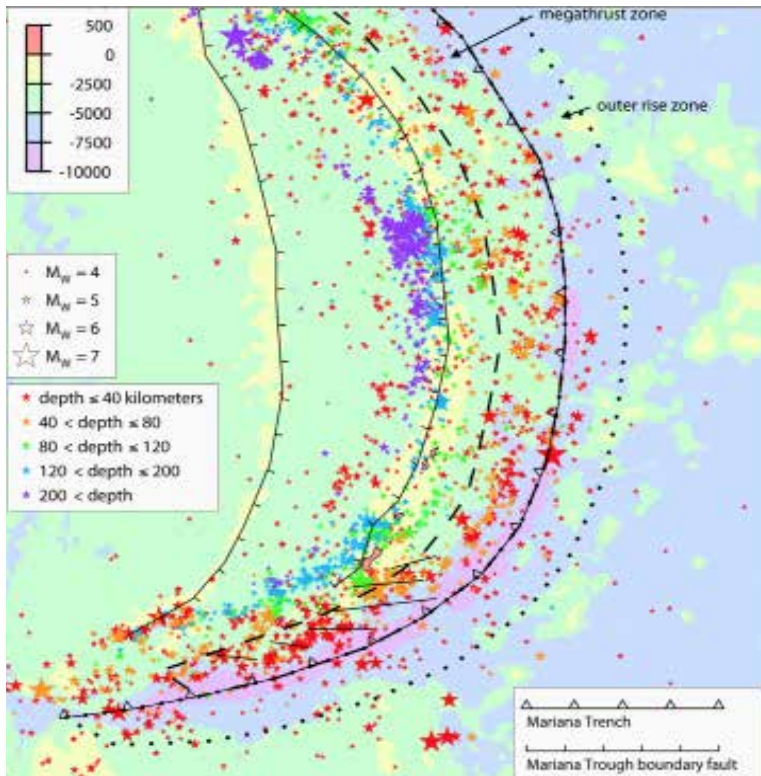

Figure 1.2. This map shows all the earthquakes that have occurred near the Mariana Islands from 1964 to 2011. Source: USGS.

*The Tsunami History of Guam* was written by James Lander, Lowell Whiteside and Paul Hattori. The authors note six other locally-generated tsunamis in the past 200 years. There was one report of a major tsunami in the late 1700s that killed several people.

The Mariana Islands are located directly west of the Mariana Trench. Two tectonic plates meet in the trench. This this day, the plates continue to move slowly. The plate movement is so slow it takes a long time for pressure to build up before being released as an earthquake. This is one reason why Guam and CNMI have not had multiple devastating tsunamis to date, although that does not mean that Guam is not susceptible to tsunamis. The location of the earthquake that causes a tsunami wave will determine where the brunt of the tsunami will make landfall. If

a tsunami approaches Guam or CNMI due to an earthquake in the Mariana Trench, most of the impact that would hit the island would be felt on the eastern side of the island.

### **Warning Time**

Local tsunamis occur within 70 miles of a location with minutes to arrival. Regional tsunamis occur within 1,500 miles or three hours to arrival time. Distant tsunamis occur greater than 1,500 miles or 8-18 hours to arrival time. You may have as little as three minutes, if the source is local. Because there is potential for very little warning time for a local tsunami, remember Nature's Own Warning. This warning system is described on pages 10 and 11.

## **How are Earthquakes and Tsunamis Related?**

Earthquakes generate tsunamis when the sea floor abruptly moves vertically and moves a lot of water instantly. The water movement creates waves. Sometimes those waves can be small, other times they can be massive amounts of moving water.

The main factor that determines the initial size of a tsunami is the amount of vertical sea floor movement. This is controlled by the earthquake's

magnitude, depth, and other plate characteristics. Other things that influence the size of a tsunami along the coast are the shoreline, the water depth near the earthquake source, and the amount and direction of energy released by the earthquake into the water.

Tsunami waves have wave length from 50-250 miles and periods (time between crest of waves) between 5 and 60 miles.

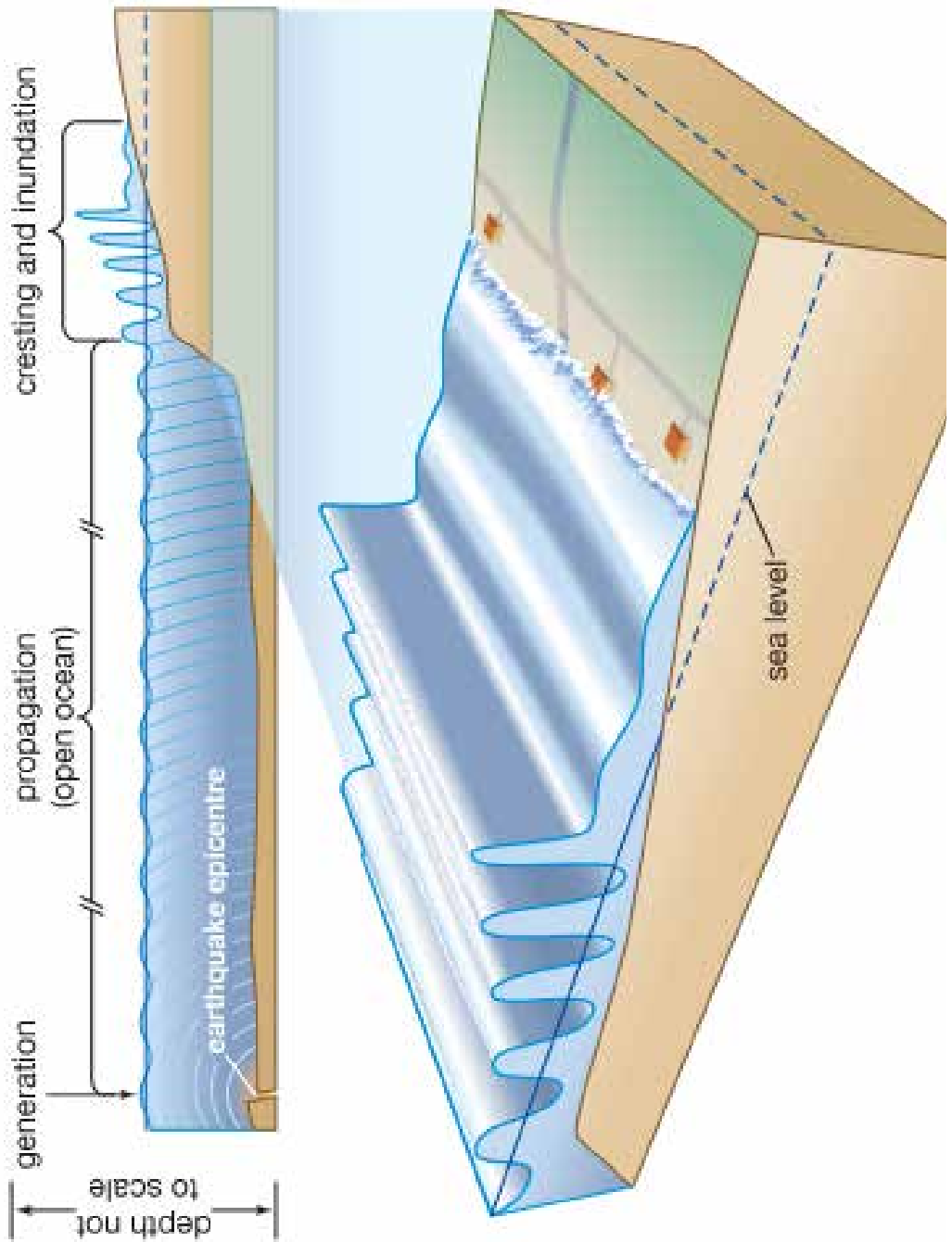

Figure 1.3. Tsunami waves are generated from an earthquake that quickly thrusts water in an upward motion. The waves crest as water approaches shore, increasing in height before they inundate land. Source: Encyclopedia Britannica.



Figure 1.4. A photograph of the 2004 tsunami in Ao Nang, Krabi Province, Thailand.  
Source: FEMA.

## **Respect the Power of a Tsunami**

A ten-foot tsunami wave will inundate much further inland than a ten-foot wind-generated wave. From a distance, the tsunami wave may not look much higher than a normal wind wave, but it will just keep coming. The tsunami may inundate an area thousands of feet inland.

A tsunami wave can wrap around the island. Even though a tsunami may be

generated by an earthquake near Japan, which is north of Guam, residents in Merizo can still be at risk.

Tsunamis come in a series of waves, each of which may be 5 to more than 60 minutes apart. The first wave is not always the largest, in fact the second, third, or fourth may be larger and more devastating.

## Nature's Own Warning System

Nature has many ways of warning us of impending danger. In the case of tsunamis, it is normal for the water in a bay or beach area to recede, or be sucked out, to sea. The power of the approaching wave sucks the water out to sea and then can rush ashore with immense speed and force. Sometimes the water level falls and rises without a violent motion.

If you have not already moved to higher ground and are witness to a dramatic and sudden receding of water from the shoreline, head for higher ground immediately. This type of event may indicate that you have less than 5 minutes to flee to higher ground.

### Lessons from History

Japan suffered catastrophic earthquakes in 1611 and 1896. Residents of the coastal towns placed stones to warn future generations. In the village of Aneyoshi, the stones specifically warn people by stating, 'Do not build your homes below this point!' The stones marked the high wave mark and serve to remind residents of the dangers tsunamis present. These tsunami stones were very useful in the 2011 Japan tsunami in Aneyoshi; the waves stopped just 300 feet below the stones.

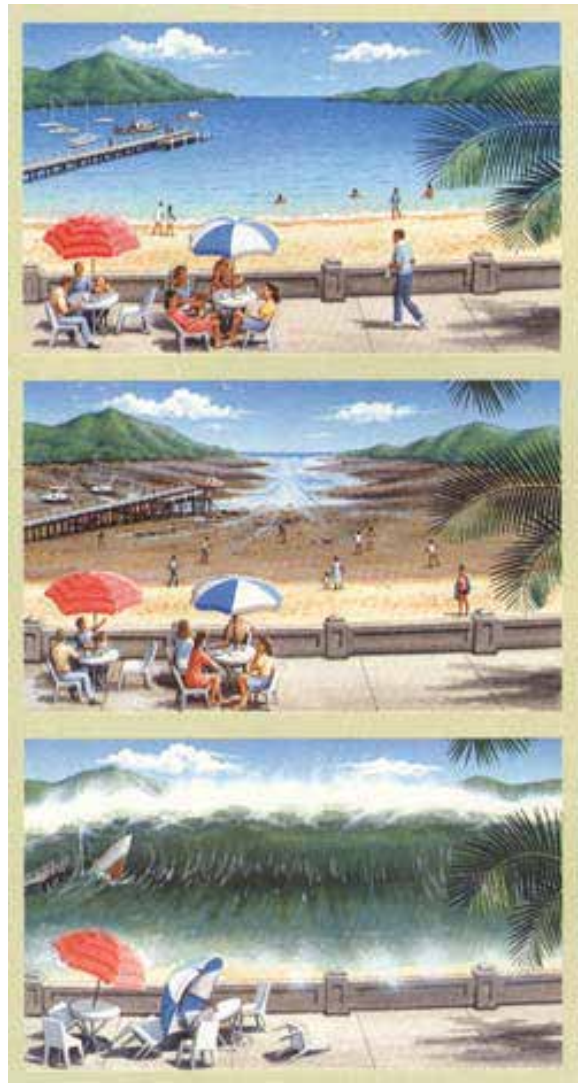

Figure 1.5. These images show a beach with a normal sea level (top), a beach being drained by a tsunami wave prior to landfall (middle), and a tsunami wave hitting land.

Source: Cal Poly Pomona, Geological Sciences.

**Table 1.1. Nature's Own Warning Evacuation Signals for Low Lying Coastal Areas\***

Nature's Own Warning	Immediate Response	Comment
Feel strong earthquake - have difficulty standing	<b>Protect yourself.</b> If in a building, drop to hands and knees to protect yourself from falling, cover your head and neck under sturdy table, desk or with arms and hands, hold on to shelter. <b>Evacuate tsunami evacuation zone after shaking stops.</b>	Any strong shaking, as measured by difficulty in standing, requires you to protect yourself, then evacuate. This is top priority. If in doubt if the shaking is strong or not, evacuate.
Feel weak earthquake	<b>Become Alert</b> - Start counting the duration of shaking in seconds. Don't turn your back on the ocean, observe the water and listen for sounds. <b>Prepare to evacuate.</b>	Feeling an earthquake is likely the first sign you receive related to a locally-generated tsunami. Yet not all earthquakes generate tsunamis.
Feel earthquake for more than 20 seconds	<b>Evacuate tsunami evacuation zone</b>	As soon as you feel weak shaking, pay attention to the duration by counting to 20 seconds. Pay attention to the ocean for unusual water changes or sounds.
Feel earthquake and rumbling noise from ocean - like thunder, truck noise or a jet airliner	<b>Evacuate tsunami evacuation zone</b>	Sound is often an early warning of imminent danger. If there is no earthquake, the noise could be real thunder, a truck, or jet.
Feel earthquake and siren	<b>Evacuate tsunami evacuation zone</b>	If no earthquake is felt, the siren is your signal to turn on local TV, radio or go online for further instructions.
Unusual disappearance of water; exposed reef	<b>Evacuate tsunami evacuation zone</b>	A later signal – the ocean doesn't always recede. May provide enough evacuation time. Better to evacuate if other signals have been observed.
Unusual wall of water	<b>Evacuate tsunami evacuation zone</b>	A later signal – wall of water doesn't always appear first. Even less time to evacuate.



**Table 1.2. Tsunami Evacuation Scenario - General Guidelines**

Source & Time	If you are at home	If you are at work	If you are at school	If you are in your car
<p><b>Local Tsunami (within 70 miles of location)</b></p> <p><b>Arrival in less than 5 minutes to 40 minutes</b></p>	<p>If inside the evacuation zone, walk out to evacuate if: (i) siren and instructions to evacuate, (ii) severe ground shaking (strong or long), (iii) earthquake and rumbling noise, (iv) earthquake and siren, (v) water recedes, or (vi) wall of water. If outside the evacuation zone, remain at home.</p>	<p>If inside the evacuation zone, walk out to evacuate if: (i) siren and instructions to evacuate, (ii) severe ground shaking (strong or long), (iii) earthquake and rumbling noise, (iv) earthquake and siren, (v) water recedes, or (vi) wall of water. If outside the evacuation zone, remain at work.</p>	<p>If inside the evacuation zone, walk out to evacuate. Evacuate if: (i) siren and instructions to evacuate, (ii) severe ground shaking (strong or long), (iii) earthquake and rumbling noise, (iv) earthquake and siren, (v) water recedes, or (vi) wall of water. If outside evacuation zone, remain at school.</p>	<p>If there is: (i) siren and instructions to evacuate, (ii) severe ground shaking (strong or long), (iii) earthquake and rumbling noise, (iv) earthquake and siren, (v) water recedes, or (vi) wall of water, then: (a) drive out of an evacuation zone; (b) once out, park in nearest parking lot or along the curb or a clear side street and stay there; (c) don't block traffic or abandon your car in the middle of the road. If necessary, pull to the side and walk.</p>
<p><b>Regional</b></p>	<p>If inside the evacuation zone, evacuate when given instructions by the radio broadcast. If outside the evacuation zone, remain at home.</p>	<p>If inside the evacuation zone, evacuate when given instructions by the radio broadcast. If outside the evacuation zone, remain at work.</p>	<p>If inside the evacuation zone, evacuate when given instructions by the radio broadcast. If outside the evacuation zone, remain at school.</p>	<p>Listen to local radio for instructions. In general: (i) drive out of an evacuation zone; (ii) once out, park in nearest parking lot or along the curb or a clear side street and stay there; (iii) don't block traffic or abandon your car in the middle of the road. If necessary, pull to the side and walk.</p>
<p><b>Chile Arrival 18-21 hours away</b></p>	<p>If inside the evacuation zone, evacuate when given instructions by the radio broadcast. If outside the evacuation zone, stay at home.</p>	<p>If inside the evacuation zone, listen to local radio as to when you should evacuate. If outside the evacuation zone, listen to local radio to determine if you should stay or when to leave.</p>	<p>If inside the evacuation zone, listen to local radio as to when you should evacuate. If outside the evacuation zone, listen to local radio to determine if you should stay or when to leave.</p>	<p>Listen to local radio for instructions. In general: (i) drive out of an evacuation zone; (ii) once out, park in nearest parking lot or along the curb or a clear side street and stay there; (iii) don't block traffic or abandon your car in the middle of the road. If necessary, pull to the side and walk.</p>

**Table 1.3. What are the Tsunami Warning Categories?**

<p><b>Tsunami Advisory</b></p>	<p>A tsunami is expected, but will not be large enough to cause significant land flooding. Evacuation of the coast is not necessary, but the beach and coastal waters may be hazardous because of unusual waves and strong currents. Sirens will not sound, but beaches will be closed. The advisory will be continued until currents fall below danger levels, which may take several hours.</p>
<p><b>Tsunami Watch (potential within 6 hours)</b></p>	<p>Issued if there is the potential for a damaging tsunami but the existence of a tsunami has not yet been confirmed. A tsunami watch will always be upgraded to a tsunami warning or a tsunami advisory or will be canceled. If it is upgraded to a warning or advisory, that upgrade will occur with a target of at least three hours before the tsunami arrives. If you learn that a tsunami watch has been issued, tune to local television or radio for further information and prepare to evacuate in case the watch is upgraded to a warning.</p>
<p><b>Tsunami Warning (expected within 3 hours)</b></p>	<p>A damaging tsunami is expected and people should evacuate from the tsunami zones. When a warning is issued, sirens will sound and the warning will be broadcast by local media. Normally a warning is issued at least three hours before the tsunami arrives; the tsunami arrival time is part of the warning and will be repeated by the media. The warning continues until wave heights have dropped below hazard levels, which may be more than 12 hours. After a damaging tsunami, the warning will be downgraded to an advisory before it is cancelled.</p>

# FLOODING

Flooding associated with heavy rains and storm surge can pose threats to people and property in the Mariana Islands. This can happen during a single storm or as part of a larger storm system like a typhoon.

Flooding can be an issue for every resident, no matter where you live. Ponding basins can fill quickly and overflow. Rivers in southern Guam can turn into raging waters with rapids, strong currents and large amounts of debris.

Flooding has been observed in Songsong Village on Rota, as well as populated areas of Saipan, including

Susupe, Tanapag, Garapan, and Lower Base. When it is raining hard and fast, be prepared. If you live near a water source or ponding basin, prepare your house. For more information on flood maps see page 65. Do not drive during a heavy rain event. Cars can easily stall in water and become hazards.

Flooding is caused by development practices, removal of vegetative land cover, impervious surfaces (i.e., cement structures, roads, and patios), and inadequate stormwater control. Flooding risks can be compounded by climate change impacts.

The National Weather Service issues flash flood watches and warnings for floods that can threaten life and property.

## How Much Rain Does it Take to Cause Flooding?

The amount of rain it takes to cause a flood depends on many things. Soil that is saturated with water, or soil that is extremely dry, is more likely to contribute to flooding.

Some areas may flood while others are totally fine. If you live near a river or ponding basin, there is a higher chance your home may flood than someone living on top of a hill. Certain areas in your village can be more likely to flood because of the concrete and clogged storm drains.

While passing over Guam in 2004, Typhoon Tingting produced torrential rains which triggered flooding and numerous landslides before striking Saipan as a typhoon.

During this storm on Guam, 21.85 inches of rain fell in 24 hours, breaking the daily and monthly rainfall records for June. One person died because of flooding. In Guam, Saipan and the other islands of the CNMI, 71 homes were destroyed and hundreds were damaged.

# TYPHOONS

Typhoons are the largest of all disasters to frequently hit the Marianas. To be categorized as a typhoon, the storm must have sustained winds of 74 miles per hour or more. Typhoons bring high winds, heavy rains, flooding and high seas. Typhoon season typically runs between June 1 and November 30, although typhoons can occur anytime of the year. In Rota, Pongsona (2002), produced gusts up to 173 mph, extensive flooding, and 22-foot storm surge at SongSong Village.

## Wind

Typhoon winds exceed 74 mph. See Table 1.5 on page 17 for more details. Typhoon Omar registered sustained winds of 120 mph (1992). These winds can destroy buildings, uproot trees and propel items through the air with deadly force.

## Heavy Rain

A typhoon can drop more than nine inches of rain in an hour and can be slow moving. If a typhoon stalls, it is possible for a typhoon to drop 18 inches or more of rain in an area. This can cause extreme flooding and severe damage.

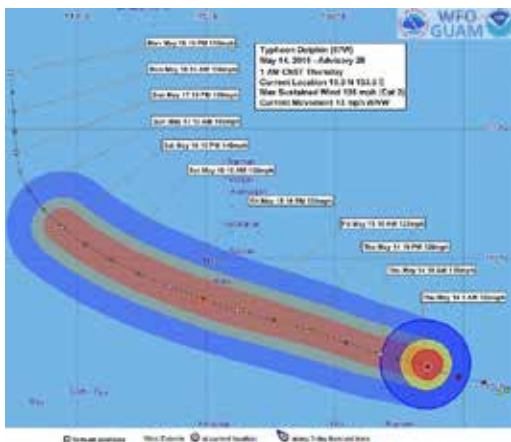

Figure 1.6. National Weather Service provides details on the estimated track of the approaching storm, when it is expected to make landfall, and the strength of winds expected. Typhoon Dolphin was a late season storm in May 2015 that tracked directly for Guam, but ended up moving north and hit between Rota and Guam. Source: National Weather Service.



Figure 1.7. Typhoon Pongsona approaches Guam on December 8, 2002. The typhoon was one of the most devastating storms in the island's history. Source: National Weather Service.

## Table 1.4. How Are Storms Classified?

<p><b>Tropical Storm</b></p>	<p>Max sustained winds at 30-73 mph. It may damage corrugated sheet metal structures, plywood, minor to moderate damage to banana and papaya trees. Sea level rise of up to 4 ft in open bays and inlets due to storm surge and wind driven waves. Category A Storm is a 'weak' storm and a Category B storm is considered severe.</p>
<p><b>Category 1 Minimal Typhoon</b></p>	<p>Max sustained winds at 74-95 mph. Corrugated metal and plywood stripped from weak structures. Few wooden, non-reinforced power poles tilted and some poles broken. 10% defoliation of trees or less. Sea level rise of 4-6 ft above normal, waves may inundate low-lying roads 2-4 ft on windward locations. Minor pier damage and small craft moorings may break.</p>
<p><b>Category 2 Moderate Typhoon</b></p>	<p>Max sustained winds at 96-110 mph. Damage to wooden and tin roofs or other weak structures. Considerable damage to structures made of light materials. Rotten power poles may snap, some power lines down, 10-30% defoliation of trees. Sea level rise of 6-8 ft above normal, waves may inundate 4-6 ft on windward locations. Moderate pier damage, large boats torn from moorings.</p>
<p><b>Category 3 Strong Typhoon</b></p>	<p>Max sustained winds at 111-130 mph. Storm may cause extensive damage to wooden structures. Some roof, window, and door damage to well-built, wooden and metal building. Air full of small flying debris. Many broken power poles, 30-50% defoliation of trees. Sea level rise of 8-12 ft above normal, waves may inundate low-lying roads 6-10 ft. Large boats and ships torn from moorings.</p>
<p><b>Category 4 Very Strong Typhoon</b></p>	<p>Max sustained winds at 131-155 mph. Storm may damage well built wooden homes and tin homes destroyed. Complete destruction of buildings made of light materials. Extensive damage to non-concrete roofs. Power poles and power lines down. Trees begin to lose bark, 50-90% defoliation. Sea level rise of 12-18 ft above normal, waves may inundate coastal areas below 10-15 ft elevation. Severe damage to port facilities including loading derricks/gantry cranes.</p>
<p><b>Category 5 Devastating Typhoon</b></p>	<p>Max sustained winds at 156-194 mph. Storm can cause total failure of non-concrete roofs. Extensive or total destruction of non-concrete and industrial buildings. Severe damage to power poles, all secondary and most primary power lines down. Sea level rise of 18-30+ ft above normal. Serious inundation likely for windward coastal areas below 15-28+ ft. Very large boulders carried inland with waves. Extensive damage to port facilities. Nearly all ships torn from moorings.</p>

## Storm Surge

Storm surge is a large dome of water pushed by a typhoon. The amount of water can exceed 20 feet depending on the strength of the typhoon. The storm surge combines with a normal tide to flood coastal areas. Add extra wind and waves to the surge and water will inundate land far beyond the high tide mark.

## Storm Classification

Storms are classified based on the strength of the winds. According to the World Meteorological Organization, maximum sustained winds equal the highest recorded wind speed over a 1-minute average, typhoon classification varies among different world populations. Table 1.4 details the classification used by the National Weather Service, or the Saffir-Simpson Tropical Cyclone scale, which applies to the Mariana Islands.

**Table 1.5. How are Typhoons Described During Warnings?**

<b>Condition of Readiness 4 (COR4)</b>	Guam and CNMI is always in Condition 4. A typhoon may develop and hit the island within 72 hours.
<b>Condition of Readiness 3 (COR3)</b>	A tropical storm or typhoon may possibly hit the island within 48 hours. General preparations should be started.
<b>Condition of Readiness 2 (COR2)</b>	A tropical storm or typhoon is expected to hit the island within 24 hours. All non-essential government agencies, including schools and the military, close. Residents are advised to go home and prepare for the storm. Women who are 36 or more weeks pregnant should go to the hospital. This is because the lower atmospheric pressure in a typhoon can cause premature labor.
<b>Condition of Readiness 1 (COR1)</b>	A tropical storm or typhoon is expected to hit the island within 12 hours. During Condition 1, only emergency traffic should be on the roads.

# CLIMATE CHANGE

Islands are particularly vulnerable to the adverse impacts of climate change impacts. Climate change may be impacting the frequency and severity of natural hazards including typhoons, droughts, heavy rainfall and floods in the region. More extreme weather can include increased coastal erosion and decreasing water quality, which can impact people and the environment. Predicted rising sea levels, altered precipitation patterns, higher temperatures and acidification of the ocean will increase these risks in

the coming decades. These changes can jeopardize the livelihoods of people, especially those engaged in tourism, agriculture, forestry, and fishing which are dependent on natural resources. Some regions are already experiencing economic and ecological impacts from changing climate conditions. While climate change is a global challenge, there are local actions you can take to adapt and reduce your risks as well as mitigate to become part of the global solution.



Figure 1.8. Storm surge eroding the shoreline at American Memorial Park, Saipan.  
Source: Robbie Green, Department of Coastal Resources Management, CNMI.

## What is Climate Change?

Climate is the long-term pattern of weather in a particular area. Climate change describes how these long-term patterns are changing. Greenhouse gas emissions – primarily from carbon dioxide (CO<sub>2</sub>), methane, and nitrous oxide, primarily from human activities, are altering the atmosphere of our planet. These gases trap the sun's heat

which is known as the greenhouse effect. This process is altering our planet's current climatic conditions, and even though it is sometimes referred to as “global warming”, it involves more than temperature; climate is determined by precipitation patterns, minimum and maximum temperatures, drought, storm intensity and more.

Like rolling up all of the windows on a bus on a hot day, the greenhouse effect traps heat that otherwise would have escaped the atmosphere increasing global temperatures.

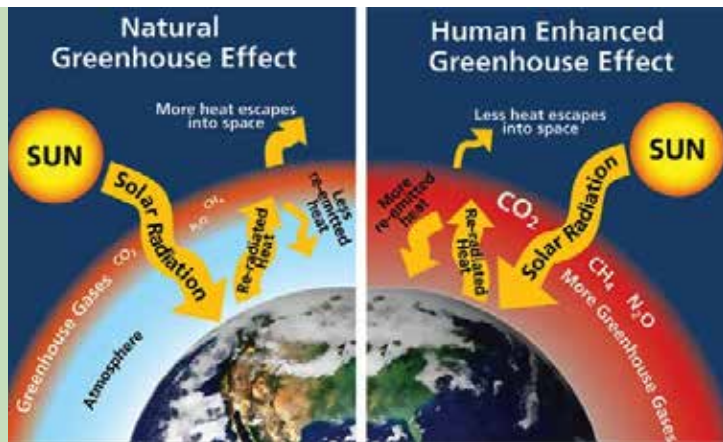

Figure 1.9. The Greenhouse effect explains how the Earth's stable climate is a product of the Greenhouse Effect by virtue of the gases trapping heat. This effect is exaggerated by human activities. Source: livescience.com.

## CLIMATE CHANGE WILL EFFECT GUAM AND SAIPAN

The potential impacts of climate change are predicted by scientist. These scientists have a high level of confidence that the Western North Pacific will experience rising sea levels, increasing air and sea surface

temperatures, and shifting precipitation patterns that will be different from the atmospheric and oceanic conditions that Micronesian Islands have built their economies, infrastructure, and natural heritage upon (see Figure 1.11). The Mariana Islands – especially more developed islands with higher populations such as Guam and Saipan – should expect and plan for change. In the summer of 2012 a “Climate Change Working Group” convened.



The Climate Change Working Group established in Saipan identified social, physical, and natural features in the CNMI that are most susceptible to the impacts of climate change. Based upon projected change and mapped features, the assessment details the exposure and

sensitivity of Saipan to these changes and the island's capacity to respond to possible impacts (see Figure 1.11). Vulnerability assessments for the islands of Saipan, Tinian, and Rota are available at: <http://www.climatecnmi.net/>.

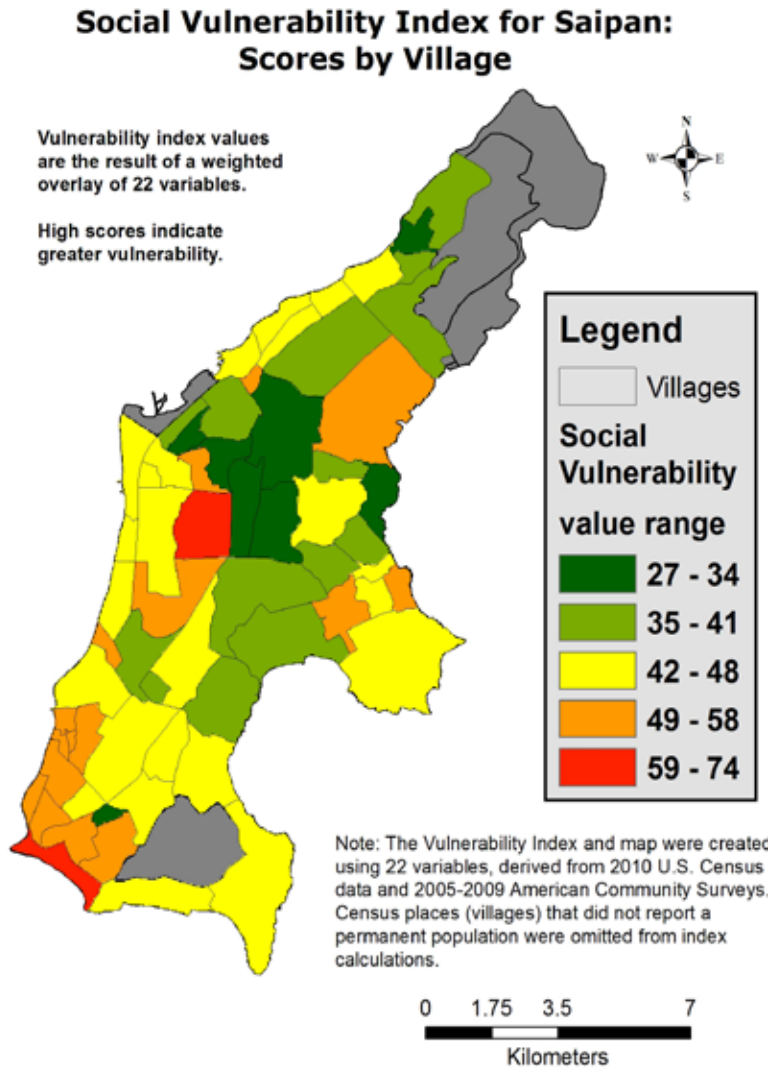

Figure 1.10. Some areas of Saipan are more vulnerable to climate change than others. For additional maps, refer to the Saipan Vulnerability Assessment (see link above).

Source: Coastal Resources Management, Saipan.

This resource is a great way to learn more about climate change in the CNMI. Efforts are underway to conduct similar assessments in Guam. Understanding potential risks can help us adapt for the future.

The CNMI assessment suggests that the villages and infrastructure on Saipan's western coastal plain are the most vulnerable to the effects of sea level rise and possible shifts in rainfall. While the entire island will likely see some impacts from climate change in the coming decades, the villages and stakeholder resources that are located between Susupe and Tanapag

are expected to be impacted the most. Specifically, the low lying areas, critical infrastructure, residential and commercial districts, and habitats that are located within Garapan and Lower Base should be prioritized as climate change adaptation planning moves forward in the CNMI.

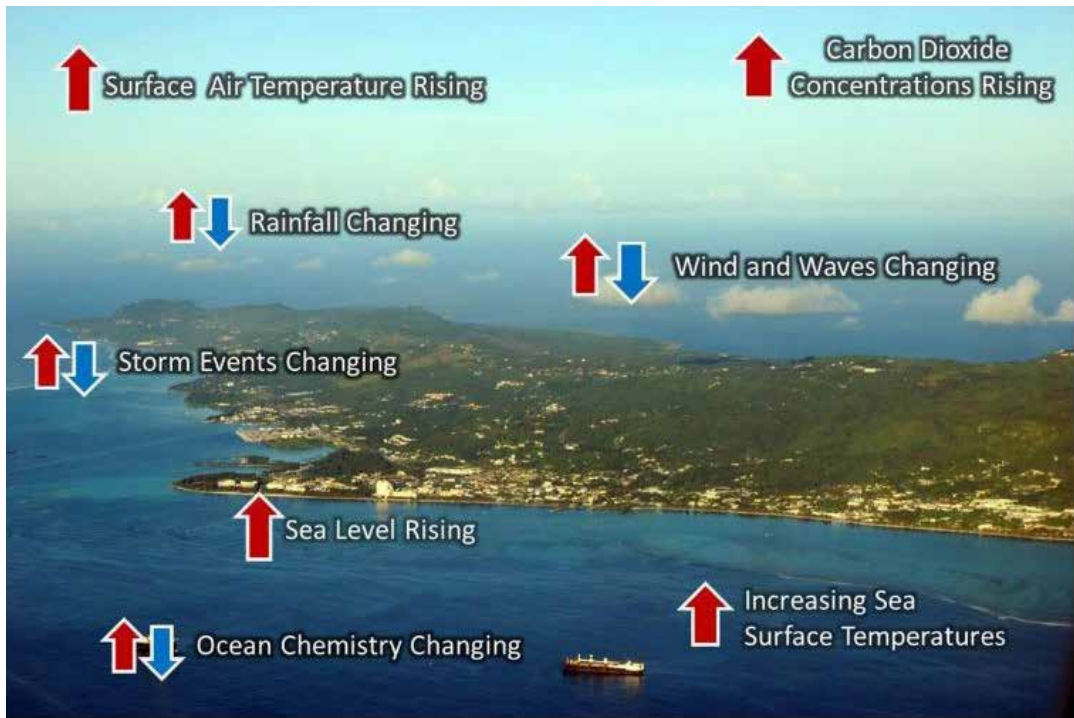

Figure 1.11. Changes in climate will vary for the region, some aspects are clear across the Pacific. Source: 2012 Pacific Islands Regional Climate Assessment.

## Adapting to Climate Change

Deliberate changes to infrastructure in response to climate stressors are examples of climate change adaptation. While a built system (e.g. freshwater pump facilities) can be altered through intentional actions, natural systems (e.g. coral reef ecosystems, wetlands, etc.) may also have the ability to change in response to climate stressors. Climate adaptation refers to efforts to improve or enhance the built, natural, or social environment to reduce risks and expand the capacity to adapt. Systems that are more able to recover from disturbance such as dramatic temperature changes or sea level rise are said to be resilient systems because they are able to bounce back from these changes and preserve critical functions.

Steps communities can take to reduce risks are:

- Prepare to manage more stormwater
- Enhance “green infrastructure” to gain natural flood protection
- Elevate or Relocate – in high-risk flood-prone areas, consider ways to elevate or relocate existing structures and develop new structures away from high-risk areas

## VOLCANOES

The Mariana Islands are located within the "Pacific Rim of Fire", an area of volcanic activity which extends around the entire rim of the Pacific Basin along the coastal fringe of the continental land masses and extending south from Japan through the South Honshu Ridge and the northern islands in the Marianas Arc. According to U. S. Geological Survey, Saipan, Tinian, and Rota are not presently within an active volcanic area. Esmeralda Bank, 24 miles west of Tinian, is the southern most active volcano in the

Izu–Volcano–Mariana Arc and is one of the most active vents in the western Pacific. It rises to within 100 feet of sea level and is considered to be an area of potential eruption or a "hot spot." Despite Tinian's proximity to the Esmeralda Bank, most of the volcanic activity occurs within the Northern Islands. In 1981 a series of eruptions on Pagan led to the evacuation of its inhabitants, and the last known eruption was in 2012. Anatahan also erupted in 2003 and 2005. As of November 2014 the USGS reported that Pagan, Anatahan, Sarigan, and Saipan have ground based monitoring equipment.

# EMERGENCY SYSTEMS, SIRENS AND AGENCIES

The Joint Information Center (JIC) is the official source of natural hazard information and instruction in Guam and the Northern Marianas. This information comes from Homeland Security and/or the Governor's office during threats or emergencies. The islandwide network may also be activated by the National Weather Service Forecast Office to disseminate weather- or tsunami-related watches or warnings.

If you hear a siren, turn on your radio. Some radios with the NOAA weather radio band turn on automatically when an emergency broadcast through the EAS is announced. This could be useful for homeowners along the coast. The NOAA weather radio station broadcasts round-the-clock weather and surf conditions, and also participates in the EAS system. For current weather and water conditions dial 211 on any phone.

Local radio stations have voluntarily agreed to participate in the JIC system. Additional information may also be available on local and cable television as well as social media outlets. See Tables 3.2 and 3.3 on pages 120-121 for more information on radio, tv, and important contacts before and after a hazard.



Figure 1.12. Sirens will announce tsunami events. This siren is recommended by FEMA for hazard awareness. In the absence of functional sirens, village mayors will alert residents. Source: Guam Department of Civil Defense.

# MAKE A PLAN BUILD A KIT

## START TODAY

Ten Simple Steps to Start.....	25
Make a Family Emergency Plan .....	26
Build a Kit.....	26
Make Evacuation Plans.....	27
Prepare Your Home for an Earthquake.....	31
Making Your Home Flood Ready .....	32
Evaluate Your Home and Property .....	35
Preparing a Wood or Tin Structure for Typhoons .....	36
Typhoon Shutters and Window Coverings.....	46
Installing Plywood Shutters .....	51
Overview of Wind Resistive Devices.....	57
Protection with Insurance.....	63



Figure 2.1. Wreckage from Pongsona in 2002.  
Source: FEMA.

Whether it is a diet or lifestyle change, starting any project can be the hardest step. When thinking about how to keep your family safe from a natural disaster, there is no better time than now to begin preparing. Starting now gives you the time to make the best choices and most preparation.

# TEN SIMPLE STEPS TO START

- 1 BE INFORMED** **Inform your family-** The more you know about the weather, tsunami warning signs, earthquakes, flooding, climate change and volcanoes, the better you can respond when a hazard occurs.
- 2 MAKE A PLAN** **Teach your family-** Anyone living in the Marianas may need to evacuate to a safer area during flooding, typhoons or a tsunami. Make a plan for each of these situations. Take the time to teach your family about what you will do if any disaster happens. See page 29.
- 3 BUILD** **A kit now-** The good news is many items you need are probably in your home already. Check and restock each month so that the supplies are complete, not outdated, or used. See page 28.
- 4 PACK** **A bag for evacuation-** Put together a bag that contains water, food, clothing, medications, personal hygiene products, and other items for five to seven days. The kit should already be assembled and checked before a natural disaster is on the way. See page 27.
- 5 BUY** **Insurance-** Don't gamble. Get insurance for a typhoon or flooding if you are in a flood-prone area and earthquakes. See page 63.
- 6 EVALUATE** **Your property-** What do you need to clean up if there was a typhoon or flooding? If the land floods, consider flood insurance. If trees overhang your house, consider trimming or cutting the branches overhead which may damage your house in a storm. See page 35 and page 74.
- 7 EVALUATE** **Your house-** Think about where you live. If you live in a concrete home, do you need to install typhoon shutters? If you live in a wood and tin structure, take steps to make it stronger. See page 35.
- 8 FINANCE** **Creatively-** Consider efforts to strengthen your house your most important home improvement project. It is a great investment to strengthen your house and increase protection for your family.
- 9 GET HELP** **from a qualified architect, structural engineer or contractor -** This handbook has projects you can do yourself. It also covers projects that you should have a qualified architect, engineer or contractor complete ([www.guam-peals.org](http://www.guam-peals.org)). Take the time to budget for these projects and protect your home, family, and property.
- 10 KEEP THIS BOOK** **in an easy-to-find place-** This handbook can help you during an emergency. Make sure you know how to find it when one arises.

# MAKE A FAMILY EMERGENCY PLAN

When a disaster strikes, your family may not be together. Children may be at school and you may be at work or on the road. Having a disaster plan for your family is very important. This plan can help everyone get to a safe place, contact each other, and decide how to get back together.

Fill out the Family Emergency Plan on page 29. You can also fill out an electronic version of this form by downloading it from the Make a Plan link at [ready.gov](http://ready.gov) (FEMA).

You should discuss the evacuation plan and practice what to do with your family once a year. If there is a major change (for example, when a member of the family goes to a new school or is working in a different location) you should update the evacuation plan.

## BUILD A KIT

It is important that your household has a stock of emergency supplies. A stock of emergency supplies is helpful during a typhoon, as well as simple power outages. Do not wait until a hazard is impending to gather your supplies, stores become crowded very quickly and often run out of supplies prior to a storm or known event. Many hazards

strike without warning, being prepared in advance is always the safer bet.

Put your supplies together now and check them monthly to make sure that they are complete, unused, and fresh. Old food and water should be used or discarded and replaced. Do not keep expired supplies. For a complete checklist that you can fill out when putting your kit together, turn to page 28.

Your emergency kit and evacuation bag can be the same thing, or you can choose to have separate kits for each purpose. The important thing is keeping your kit(s) stocked and easily accessible.



Figure 2.2. Tsunami Assembly Area signs show you safe places to gather during an evacuation from a tsunami. These signs are posted in many places in Guam. Source: FEMA.



Figure 2.3. A Red Cross "ready to go" preparedness kit showing the bag and its contents. From left to right: bottled water, emergency meals, gloves and a dust mask, backup batteries, flashlight, portable radio, whistle, protective eye covering, an emergency blanket and an emergency poncho. All of these items are useful during an emergency situation. Look at your individual needs and determine if there are items that would be useful in your kit including, multiple pairs of gloves, multiple flashlights and nonperishable food items. You do not necessarily need to buy new things to pack in your kit. Find these items around your home. Source: American Red Cross.

## MAKE EVACUATION PLANS

Your family may not be together when a disaster strikes so it is important to plan in advance: how you will get to a safe place; how you will contact one another; how you will get back together; and what you will do in different situations.

You should also inquire about emergency plans at places where your family spends time: work, day care and school, faith organizations, sports

events and commuting. If no plans exist, consider volunteering to help create one. Include all able-bodied persons (men, women, and children) in your plan found on page 29. Help everyone in one in your household understand what they need to do if a hazard is possibly on the way.

### **Pack an Evacuation Bag**

The evacuation bag is what you will take if you have to leave your house in an emergency. Your evacuation kit should be checked every few months. It should be in a duffel bag or backpack, so it is ready to go immediately. Your



## Table 2.1. What do You Need in Your Emergency Kit?

- Two (2) copies of your family emergency plan (see page 29)
- Personal ID for all
- Cash for purchasing incidentals
- Extra copies of insurance papers, list of prescriptions, and family health records
- First aid kit and manual prescription and nonprescription medicines for at least 7 days
- Extra pair of glasses/contact lenses
- Three (3) gallons of water per person
- Seven (7) day supply of non-perishable foods
- Manual can opener
- Flashlight and extra batteries
- Candles and matches
- Multi-tool or wrench/pliers
- Personal hygiene items
- One (1) comfort item per child
- Pet supplies

### Additional Items to Consider:

- Whistle to signal for help
- Spare set of car and house keys
- Paper cups and plates and plastic utensils
- Portable gas stove with cans of fuel
- Blankets or sleeping bags
- Baby wipes and/or hand sanitizer
- Plastic trash bags
- Change of clothes and rain gear
- Sunscreen and insect repellent
- Additional play items for children
- Special items for infants
- NOAA Hand-crank Weather Radio

NOTE: FEMA recommends a three (3)-day supply of food and water, however, because of the Marianas geographic isolation it is recommended to prepare for at least seven (7) days.

# Family Emergency Plan

<p><b>Family members</b> <i>(List everyone living in your home)</i></p>	<p><b>Name:</b> _____ <b>Date of Birth:</b> _____  <b>Social Security #</b> _____ <b>Phone:</b> _____</p> <p><b>Name:</b> _____ <b>Date of Birth:</b> _____  <b>Social Security #</b> _____ <b>Phone:</b> _____</p> <p><b>Name:</b> _____ <b>Date of Birth:</b> _____  <b>Social Security #</b> _____ <b>Phone:</b> _____</p> <p><b>Name:</b> _____ <b>Date of Birth:</b> _____  <b>Social Security #</b> _____ <b>Phone:</b> _____</p> <p><b>Name:</b> _____ <b>Date of Birth:</b> _____  <b>Social Security #</b> _____ <b>Phone:</b> _____</p> <p><b>Name:</b> _____ <b>Date of Birth:</b> _____  <b>Social Security #</b> _____ <b>Phone:</b> _____</p>
<p><b>Other important phone numbers</b></p>	<p>Off island family: _____  Family doctor: _____  Pharmacist: _____  Medical insurance: _____</p>
<p><b>Where is everyone during the day and where do we meet if there is an emergency?</b></p>	<p><b>Work #1:</b> _____ <b>Village:</b> _____  <b>Phone:</b> _____ <b>Evacuation location:</b> _____</p> <p><b>Work #2:</b> _____ <b>Village:</b> _____  <b>Phone:</b> _____ <b>Evacuation location:</b> _____</p> <p><b>Work #3:</b> _____ <b>Village:</b> _____  <b>Phone:</b> _____ <b>Evacuation location:</b> _____</p> <p><b>School #1:</b> _____ <b>Village:</b> _____  <b>Phone:</b> _____ <b>Evacuation location:</b> _____</p> <p><b>School #2:</b> _____ <b>Village:</b> _____  <b>Phone:</b> _____ <b>Evacuation location:</b> _____</p> <p><b>School #3:</b> _____ <b>Village:</b> _____  <b>Phone:</b> _____ <b>Evacuation location:</b> _____</p> <p><b>Other #1:</b> _____ <b>Village:</b> _____  <b>Phone:</b> _____ <b>Evacuation location:</b> _____</p> <p><b>Other #2:</b> _____ <b>Village:</b> _____  <b>Phone:</b> _____ <b>Evacuation location:</b> _____</p>

evacuation bag may be different than your emergency kit. The American Red Cross recommends that the evacuation bag have supplies for seven days.

There is a fine line between bringing too many supplies that overload the limited shelter space of 10 square feet per person and not bringing enough. However, if you go to a shelter, keep in mind that there will be limited space, so bring only what is recommended unless you are instructed otherwise by your civil defense or emergency management agencies.

Consider how family members will communicate if they become separated. Each family member should have a copy of the emergency plan in their car, office or backpack. If cell phone service is limited, send a text. Text messages take up less bandwidth and will be delivered when service becomes available. It is also advisable to keep a corded phone on hand or in use. If the power goes out, cordless phones will not work. It is also worthwhile to check your phone provider, as some service providers utilize cable based phone service, which will not be functional during power outages.

If needed, develop a plan to help family members who have a disability or those with limited mobility. If family members are with a care-provider, confirm that the care-provider has an evacuation plan. Otherwise, you, your

family, your friends or relatives, or someone nearby who is designated can take responsibility for that person(s).

Develop a plan for your pets. For most disaster evacuations, except going to a typhoon shelter, you will need to take your pet with you.

### **Evacuating Pets**

If you need to evacuate, you will need to take your pets with you. Most shelters will not take pets so you have to find a safe place for them with family, friends or a boarding facility. For a list of animal boarding facilities see page 122.



Figure 2.4. A NOAA weather radio can be useful during hazard events. The radios are very functional when power is out with a hand crank and solar panels (some models). In emergency situations, the radios will come on automatically to provide updates.

Source: NOAA.

# PREPARE YOUR HOME FOR AN EARTHQUAKE

## **Fasten Shelves, Bookcases and Tall Furniture to Walls**

Place large or heavy objects on lower shelves. Use flexible straps to secure items so they sway without falling to the floor.

## **Store Breakable Items**

Bottled foods, glass, and china should be in low, closed cabinets with latches.

## **Secure Items to the Wall**

Mirrors, picture frames, and other hanging items should be secured to the wall with closed hooks or earthquake putty. Do not hang heavy objects over beds, sofas, or any place you may be seated.

## **Brace Expensive Electronics**

Electronics such as computers, televisions and microwave ovens are heavy and expensive to replace. Secure them with flexible nylon straps. Brace overhead light fixtures and top heavy objects.

## **Repair Lines**

Repair defective electrical wiring and leaky gas connections. These are potential fire risks. Do not work with gas or electrical lines yourself.

## **Care for People and Pets**

Learn first aid, know how to use your home fire extinguisher, and how, where, and when to shut off your home's utilities.

## **Use Flexible Plumbing Fittings**

Install flexible pipe fittings to avoid gas or water leaks. Flexible fittings are more resistant to breakage.

## **Repair Roof and Wall Cracks**

Repair any deep cracks in ceilings or foundations. Get expert advice if there are signs of structural defects. Get professional help to assess the building's structure and then take steps to install non structural solutions, including foundation bolts, bracing crippled walls, reinforcing chimneys, or installing an earthquake-resistant bracing system for a mobile home.

## **Store Chemicals Safely**

Store weed killers, pesticides, and flammable products securely in closed cabinets with latches and on bottom shelves (see Table 5.5).

## **Locate Safe Spots in Rooms**

Locate safe spots in each room under a sturdy table or against an inside wall away from windows, mirrors, and other breakables. Reinforce this information by moving to these places during each drill. Doorways are not regarded as safe shelter locations.

## **Practice Earthquake Drills**

Hold earthquake drills with your family members: DROP, COVER, AND HOLD ON.

# MAKING YOUR HOME FLOOD READY

## **Check the Drainage on Your Property and Around Your Home**

In many cases flooding on a property can be caused by poor drainage. If this is the case, it may be of great benefit to address the drainage issue with the professional advice of a licensed civil engineer. See page 65 for more information on flood maps and flood insurance.

## **Inform Local Authorities**

Inform the local mayor's office (or even neighbors) of any special needs that your family may have (i.e. elderly or people with a disability).

## **Safeguard Your Important and Valuable Items**

Create a flood file containing information about all your possessions and keep it in a secure place, such as a safe deposit box or waterproof container. Make sure the file has a copy of your insurance policies with your agent's contact information.

## **Have Copies of Financial Records and Other Purchase Information**

Copies of all other critical documents, including finance records or receipts of major purchases.

## **Make a Household Inventory Sheet**

For insurance purposes, be sure to keep a written record and photographs of all major household items and valuables.

Create files with store receipts for major appliances and electronics. Have jewelry and artwork appraised. These documents are critically important when filing insurance claims. For more information, visit [www.knowyourstuff.org](http://www.knowyourstuff.org).

## **Clear Debris From Gutters**

Clear debris from gutters, downspouts, roof and deck drains.

## **Elevate Electrical Components**

Raise your electrical components (switches, sockets, circuit breakers, and wiring) at least 12 inches above your home's projected flood elevation.

## **Put Appliances on Blocks**

Place the water heater, washer, and dryer on cement blocks at least 12 inches above the projected flood elevation.

## **Practice Evacuation Drills**

Have members of your family practice exiting the premises in the event of a flood or flash flood.

## Table 2.2. Evacuation Review

Earthquake	Tsunami	Typhoon	Flood
If you are inside, duck, cover and hang on. Stay clear of windows, heavy furniture and appliances. If you are outside, get out into the open, away from tall structures and power poles.	When a siren sounds, listen to the radio and follow the instructions carefully. Avoid driving. If you are outside of the evacuation zone, stay there.	Determine if your home is strong enough to keep you safe during a typhoon. If not, shelter with family or at a village shelter before the storm hits.	If you live near a river, in a low area or in a home that has flooded before, know where you can find safe shelter if your home floods. Evacuate before it is too late.



Figure 2.5. Extensive damage in Tumon caused by Super Typhoon Pongsona. Deciding to reinforce your home and prepare your property for a storm is a good idea. Storms can be intense and potentially deadly. Take the time to prepare your family and decide if you would look for shelter somewhere other than your home.

Source: FEMA.



Figure 2.6.a. Take the time to evaluate if your home and property would survive a storm or earthquake. The photo above was taken after Typhoon Paka. Source: FEMA.

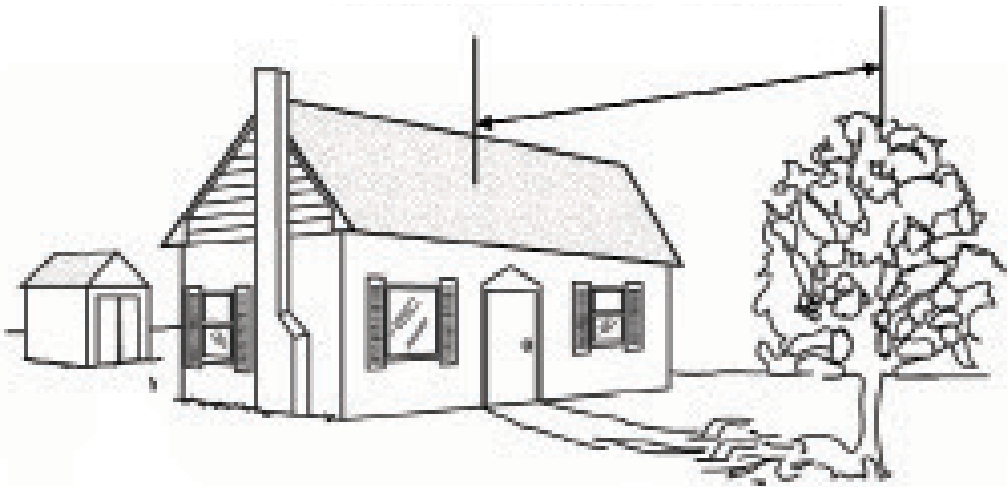

Figure 2.6.b. The drawing above shows that the distance of trees to the home should be greater than the height of the tree to minimize damage to the home from fallen trees. How safe is your home? Take steps today to make it safer. Source: FEMA.

# EVALUATE YOUR HOME AND PROPERTY

Protecting your property and protecting your family go hand in hand. Your house may be able to provide shelter from many weather conditions.

Concrete homes are more likely to withstand severe conditions. Wood and tin structures may leave residents more vulnerable under certain conditions.

By strengthening your house, you may be able to shelter in place during a typhoon. The amount of protection your house can provide is limited by a number of factors, some of which are listed below.

## **The Severity of the Hazard**

Protecting against a tropical storm or Category 1 typhoon will be much easier than against a major Category 4 or 5 storm (see page 16). For stronger storms, eliminating all damage is very difficult and the major goal is to significantly lessen the amount of damage. Also, many small improvements can significantly reduce the risk of damage and/or injury.

## **Your Location**

Even though a typhoon may be a Category 1, you could experience strong wind. Being on a ridge, for example, amplifies the wind speed.

## **How Your House Was Built**

**Concrete structures are much stronger** than wood and tin structures. Look at all parts of your home and try to determine which parts would be weakened by a typhoon or flood.

## **How Your House Was Maintained**

Maintenance of your house is important. Rotting wood or concrete with water seepage can weaken the structure of your house. Painting the exterior every few years protects the concrete or wood and prevents rot and seepage. Termites can also weaken a wood-framed house. If the wood in the house is rotten or has severe termite damage, it will be more difficult, or even impossible, to strengthen the house in a retrofit. Proper maintenance will extend the life of a house in more ways than one.

## **Tree Trimming**

Falling tree limbs or branches can significantly damage a house, see Figure 2.6. Trim trees so that air can flow through. If the branches and vines are too thick, the air cannot flow through, the tree will act like an umbrella and catch the wind before it topples over. Generally, you should hire a tree trimmer to perform this work.



# PREPARING A WOOD OR TIN STRUCTURE FOR TYPHOONS

Even if your wood house was not built with concrete walls or hurricane clips, there are many small steps, and some major ones, that can be taken to address some of your home's weaknesses. This section includes tips to strengthen your house. For many homeowners, even minor damage of 15% or less can be an extreme hardship.

The two most important things you can do to strengthen your wood structure or wood house are:

- Create a continuous load path
- Create a wind and rain resistant envelope around your house

If all houses in Guam and CNMI were properly designed and fitted with hurricane clips, wall-to-foundation connections, and window protection, perhaps hundreds of homes that have been destroyed in past typhoons could have been saved, and thousands that suffered severe, moderate, or minor damage may have instead had moderate, minor, or no damage, respectively.

Typhoon, or hurricane clips, (also known as straps or ties) are pieces of sheet metal that are fastened with nails or screws to the roof and the wall. Simpson Strong-Tie is a well known manufacturer of these clips that can be found at hardware stores (see Figure 2.15).

For houses without hurricane clips, it is encouraged to add them to prevent the roof from blowing off. You can hire a licensed contractor to do the work. You can also do the work yourself.

Figures 2.10 and 2.13 are examples of an easy installation. When installed as such, the clips provide 400 lbs. of uplift protection per rafter. Thus, even the roof of a very old wood and tin house can be tied down. For most wood and tin houses, two people can do the simple installation in two or three Saturdays with a materials cost of under \$300, excluding power tool costs. For those that do not have the time, companies performing this work may be able to do the work for about \$2,000. Costs subject to change.



Figure 2.7. A church receives major damages on the island of Guam caused by Super typhoon Pongsona. Below: FEMA representatives talk with residents of Merizo after the typhoon. Photographs by © Andrea Booher / FEMA News Photo. Guam, December 15, 2002.



You may be able to perform the work to incorporate many of the measures detailed in this chapter. However, if the work is beyond your capabilities, consider hiring a licensed contractor, structural engineer, and/or architect ([www.guam-peals.org](http://www.guam-peals.org)). Even if you do this work yourself, it is best to contact one or more of these professionals first to obtain guidance and details specific to your house.

**Summary:** Almost every wood and tin house in the Marianas can be strengthened with typhoon clips to prevent the roof from blowing off.

### **Continuous Load Path**

The concept of continuous load path connection is illustrated on the next page. The load path provides a continuous connection between your roof and your house's foundation and helps to keep the roof from blowing off during a typhoon.

The continuous load path connection is analogous to a chain: both are only as strong as their weakest link. Historically, the weakest link has often been the roof-to-wall connection. Thus, the hurricane clip was created.

### **Create the Wind- and Rain-Resistant Envelope**

In many instances, loss of glass windows or doors, either from direct wind pressure or from debris impact, resulted in breach of the building

envelope, subsequent internal pressures, and progressive structural failure.

During a typhoon, it is very important to protect the envelope of your house from wind and rain. Windows can serve to protect that envelope, unless they shatter, which is almost certain to happen if they are unprotected. Taping your windows will not protect that envelope. A broken window during a typhoon can be devastating in several ways: besides the incoming typhoon-force wind and torrential rain in your living room, there is shattered glass and debris from outside flying in. It can make walking in your own house hazardous.

Some reports indicate that a window breach can potentially double the uplift forces on your roof and can significantly increase the chances that your roof will lift off. This is why FEMA indicated in their assessment report that breach of the building envelope and subsequent internal pressurization led to progressive structural failure for many houses.

Some options to strengthen your house include:

- roof-to-wall connections (for example, typhoon clips)
- roof protection
- garage door and window coverings and foundation upgrades.

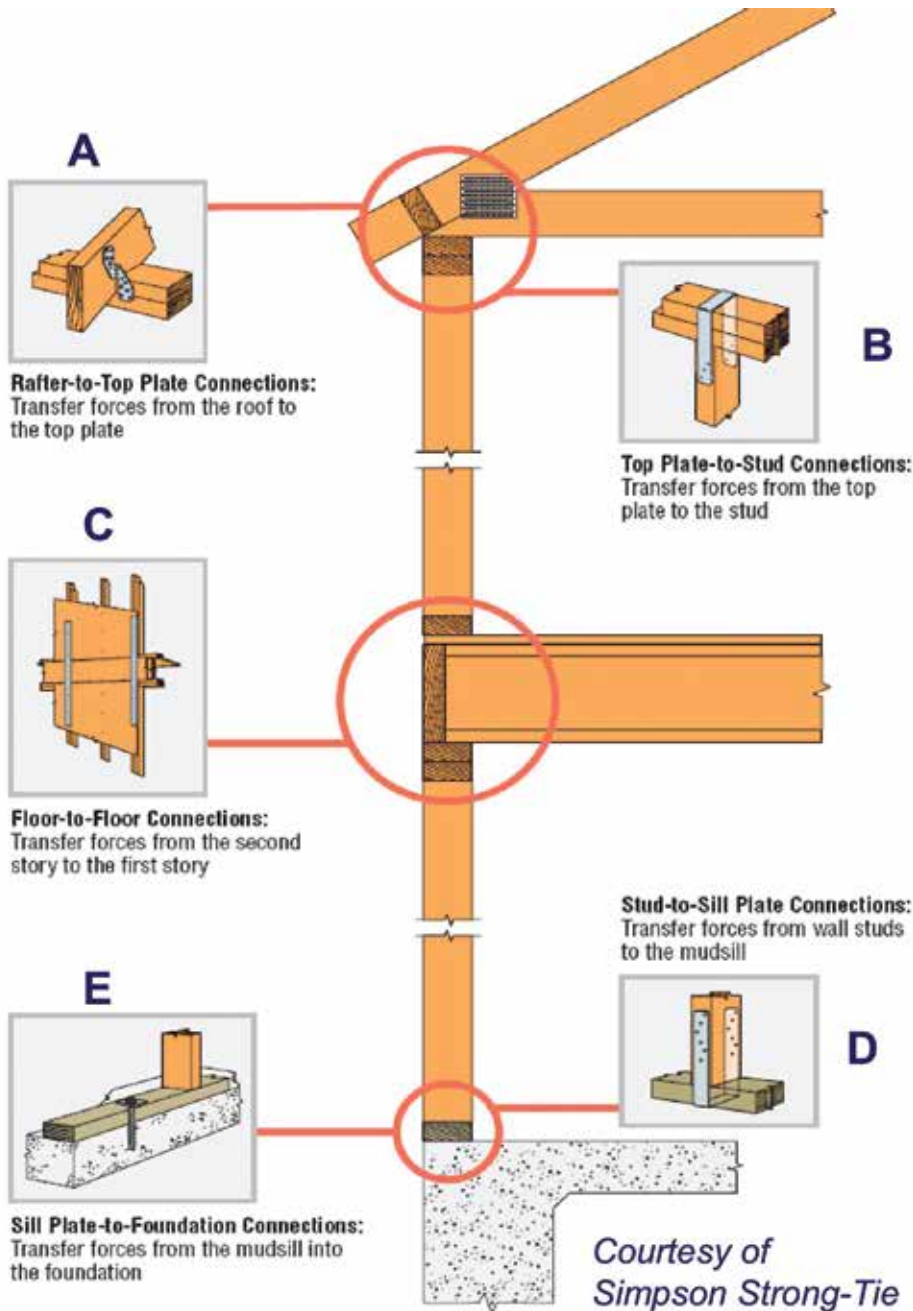

Figure 2.8. Continuous load path connection tie examples. Clips tying the roof to the wall (A, B), the wall of a higher story to the wall of a lower story with straps (C), the wall to the foundation with plate ties (D) and anchors (E). For a single story house, the connections at C are not needed. New homes may have these ties, older homes may not and could be retrofitted. Source: Simpson Strong-tie.

## Installing Hurricane Clips

### **Ask an Architect or Engineer**

Consult a licensed architect or structural engineer to confirm the specifications for your house ([www.guam-peals.org](http://www.guam-peals.org)). The guidelines in this book are general.

### **Only Do It Yourself if You are Capable**

It is not difficult to install clips, but labor is required. Having two people do the work makes it easier. This is work that must be done months before a typhoon is on the horizon to ensure proper supplies are in stock and you have ample time for installation.

### **Always Think of Safety**

Wear eye protection (goggles) and hearing protection (ear plugs or ear muffs). Ladders should be sturdy and in good condition.

### **Use Good Equipment**

You don't need professional tools, but using modern tools will make putting the ties in more efficient and enjoyable. If you don't have tools, find some to borrow or rent from a hardware store.

### **Use Clips with a Galvanized Coating**

The hurricane clip has a galvanized coating and costs under \$1 each (H1 clip). Other types of specialized clips cost between \$1-3. The stainless steel version is for maximum corrosion resistance and should be used for those living near the coastline.

### **If You Paint the Clips, Use a Primer First**

Some homeowners do not paint the clips and install them in their original condition. Others paint them to match the color of the rafter, which can be done by first covering with a primer for galvanized metal, or spray Plasti-Dip. This is followed by painting the clip which provides corrosion protection and is more visually pleasing (see Figure 2.12).

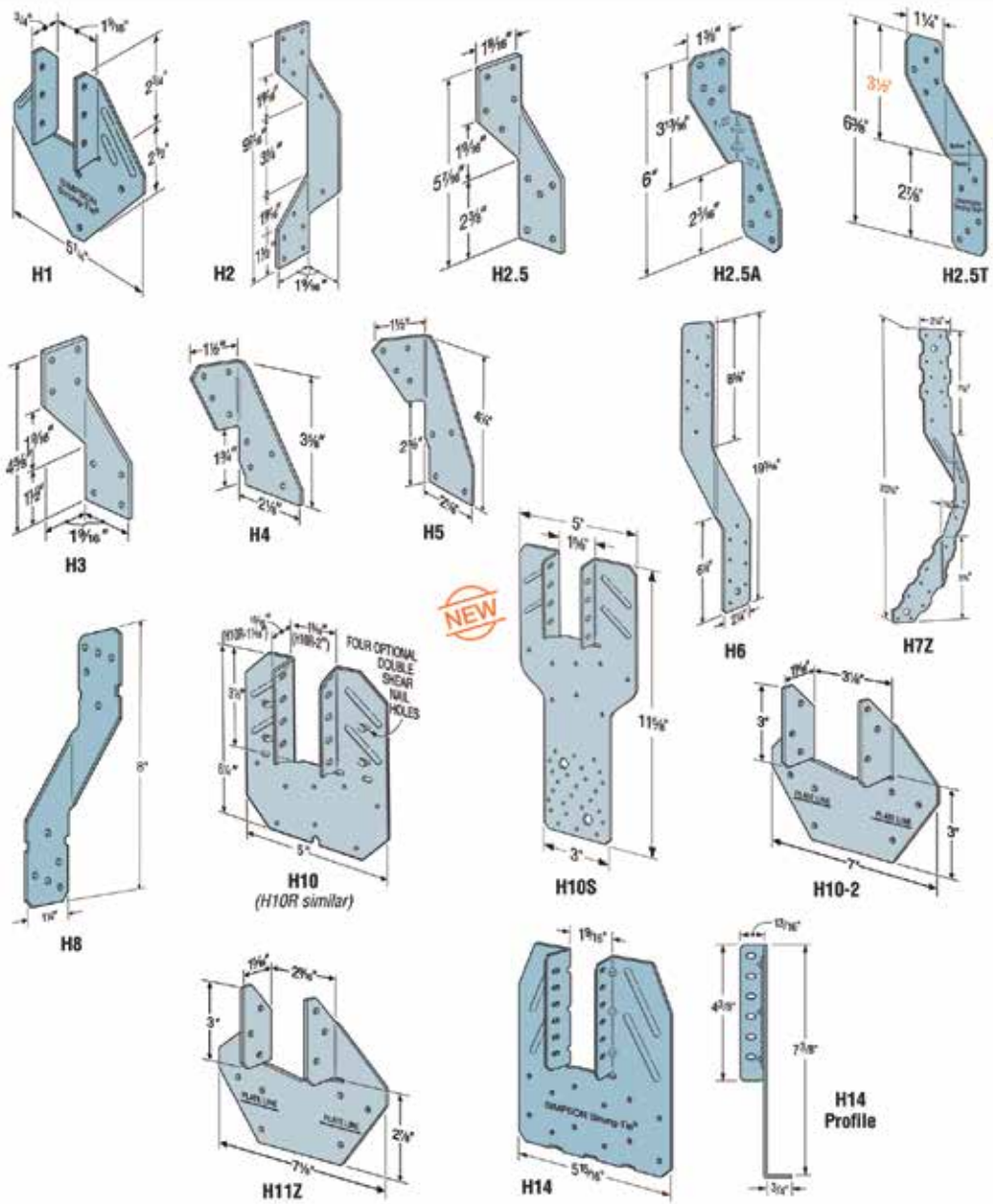

Figure 2.9. There are many different types of typhoon clips. A licensed architect, structural engineer or contractor can tell you what is best for your house and for the amount of protection you want. Source: Simpson Strong-tie.



Figure 2.10. This popular H2.5 typhoon clip installed during new construction. Five nails are hammered into the lower beam (or top plate) and five more needed to be used for the roof (truss-rafter) connection. A typhoon clip is required for each truss-rafter. Upon completion of this structure, the hurricane clip will be hidden from view. This particular clip costs \$.30. For less than \$1 in material costs, stronger ones can be installed for both new and homes being retrofitted. Source: Figures 2.10-2.12, 2.15-2.20 University of Hawaii Sea Grant.



Figure 2.11. This is an example of retrofitting an existing house, originally built without typhoon clips. The popular H3 clip is used here; four nails attach the clip to the roof (truss-rafter) and four more nails attach to the wall or top plate below. For a retrofit, the clips are exposed on the outside of the house, therefore, both the clip and fasteners should be corrosion resistant and painted to blend with the exterior of the house. With the correct clip and nails you could perform the work or if you prefer, hire a licensed contractor.



Figure 2.12. In this retrofit example, a hurricane clip attaches the roof structure to a horizontal ridge beam, which is in turn attached to the vertical post with a metal strap. This is an attempt to tie the load from the roof to the foundation, or create the complete load path connection. Note that these clips and straps are in the process of being painted.



Figure 2.13. In some retrofit examples, it is possible to tie a portion of the house to the foundation. Here, a metal strap connects the vertical post to the foundation, which attempts to finish the continuous load path connection from the roof to the foundation. The strap has been primed and painted. Source: Hurricane Protection Services.

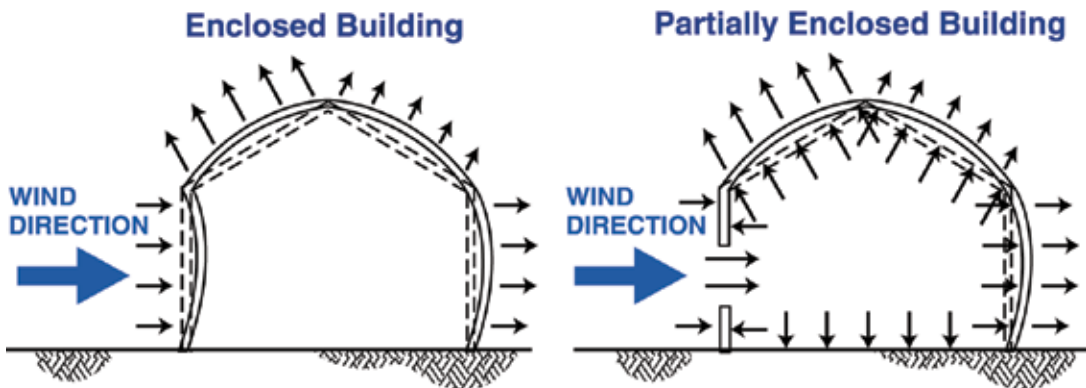

Figure 2.14. This figure shows the importance of protecting your windows. The diagram on the left shows a structure with the wind and rain resistant envelope intact. Pressure on the walls and roof comes from the outside only. In the diagram on the right, the structure's wind and rain resistant envelope has been breached due to a broken window. Now, pressure on the walls and roof comes from outside and inside. The total amount of pressure increases significantly and can lead to the roof flying off and complete structural failure. Source: FEMA's Coastal Construction Manual (2000).



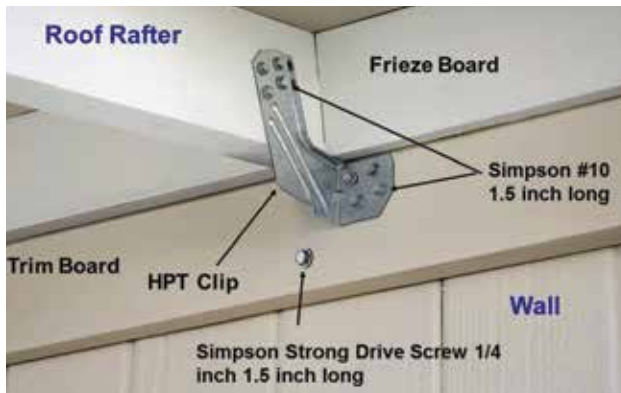

Figure 2.15. The Simpson HPT clip connects the roof rafter to the wall. Because the frieze board protrudes and is at an angle to the wall, the simpler-to-install H3 clip cannot be used. Note the edge of the individual tongue and groove boards for this single wall house. The #10 and  $\frac{1}{4}$  inch screws are screwed into the same board as the HPT clip.



Figure 2.16. For the installation above, a right angle impact driver (A) is used to install the manufacturer's specified connections. Eight  $\frac{1}{2}$  inch length screws (B) are used for the top tab and bottom tab. One  $\frac{1}{4}$  inch  $1\frac{1}{2}$  inch long screw (C) provides connection from the trim board to the wall. The HPT clip (D) is also shown.

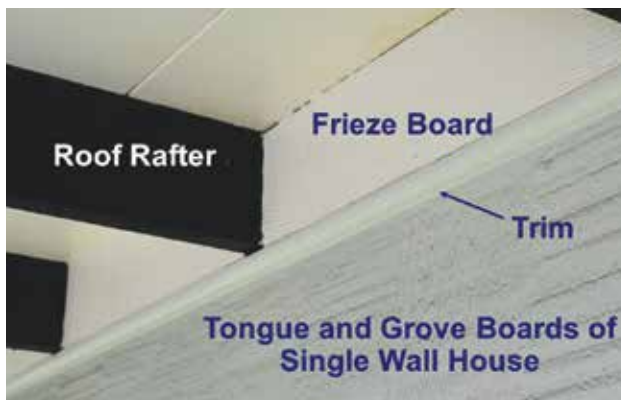

Figure 2.17. In the more difficult installation, the molding needs to be removed and replaced with a trim board so the 1.5 inch screws don't penetrate through the wall of the single wall house, which is typically  $\frac{3}{4}$  to  $1\frac{1}{2}$  inch thick.



Figure 2.18. In an installation where the molding needs to be removed, it is easily done with a multi-tool (E) and a nail-trim remover (F).



Figure 2.19. The old trim has been pulled off. The new trim is 1 inch by 4 inch exterior wood, treated for termites, painted with primer and two coats of paint that match the wall. Color matching can be done by taking a small sample to your local hardware store.



Figure 2.20. With the proper trim, the HPT clips can be installed as shown. Every rafter is connected to the wall in a visually pleasing way. Adding trim is not hard to do but will double the installation time. Two people working on this project could probably complete it in about three to four days.

# TYPHOON SHUTTERS AND WINDOW COVERINGS

Since protecting the wind- and rain-resistant envelope of your house is so important, information is provided here on window coverings. At this point, it is necessary to go over the various options. Pricing may vary between vendors and may change over time. Check with the manufacturer that the coverings to be installed are tested and approved to meet industry standards for typhoon impact. Always use only licensed contractors and reputable dealers.



## Laminates

Laminates can be placed over existing windows. For laminates, the amount of protection is a function of the thickness of the film and the type of glass being protected (safety glass versus plate glass).



## Accordion Shutters

Accordion shutters are similar to roll-down shutters in that the shutter unit is housed along the edge of the window. For roll-downs, however, the shutter is housed on the top of the window, while for accordion shutters, it is stored on either side. Source: Window Covering Images, University of Hawaii Sea Grant.



## Roll-down Shutters

Roll-down shutters are permanently attached to a building. They are housed above the window. During an emergency, roll-down shutters are fast. The shutter is held in place by guide tracks along the sides of the window and secured at the base by a latch on the guide track. Some shutters are lowered electrically, others, manually.

## Colonial Shutters

For many homes in Guam, colonial shutters have many of the advantages of quick deployment, aluminum panels, while being more esthetically pleasing.

Colonial shutters are typically made of aluminum or fiberglass. During a storm, the panels are closed and secured along the vertical center of the window. During good weather, the panels open along hinges on the side of the window and rest flat against the wall in a decorative manner.



## Storm Panels

Storm panels were originally made of aluminum or steel, but now come in clear plastic also. The panels are corrugated and overlap for extra strength. Although the panels require storage when not in use, they usually stack together. The clear plastic panels are an especially attractive option for homeowners in the Marianas since they allow light to go through while providing strong protection from flying debris from a typhoon. They are a good option for the first floor of houses or wherever there is easy access.





### **Typhoon Mesh, Screen, or Fabric**

The screen can cover large areas and provide protection to windows with unusual configurations. In this case, one option would be to use a typhoon screen, mesh, or fabric. This screen usually consists of woven polypropylene or a resin coated ballistic nylon. Light can pass through the fabric so that the area inside is not totally dark. The fabric is also lightweight and can be taken down or put up quickly by one person.



### **Plastic Honeycomb Panels**

A relatively recent development in window protection are plastic honeycomb panels made of polypropylene. These panels are installed like plywood and have many of the benefits, with few of the disadvantages of plywood. The panels can be clear or white.



### **Impact-Resistant Glass**

Many hardware and home improvement stores offer the option of purchasing windows with impact-resistant glass as a replacement for existing windows. These windows come in a variety of styles, options, and costs, and are laminated to increase the impact strength of the glass. Impact resistant glass can still break during typhoon or earthquake conditions on Guam. This type of glass is not intended to be used in place of wind shielding devices such as typhoon shutters.

## Plywood Shutters

One of the most commonly used options for window protection is regular plywood. Plywood offers good protection if properly installed. The material cost is the least expensive of any of the other options discussed.

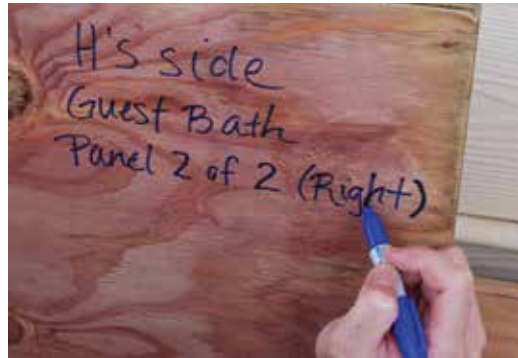

**Table 2.3. Pros and Cons of Types of Window Protection**

Type of Protection	Pros	Cons	Cost for 3 ft. x 4 ft. window
<b>Accordion Shutters</b>	Easily deployed. Good protection	Esthetics. May need homeowner association approval.	\$300 to \$360
<b>Roll-down Shutters</b>	Easiest to deploy. Good protection.	Most expensive of permanent shutter systems. Needs manual backup for power outages or an emergency power source. May need homeowner association approval.	\$360 to \$600
<b>Laminates</b>	Storm, security, and UV protection. Energy efficient. Always on. Allows light in. Ideal for hard-to-reach windows.	Other systems are stronger. Need to lock laminate to frame. Frame must be strong. Window may need replacement after storm.	\$180 to \$204

**Table 2.3. Pros and Cons of Types of Window Protection cont'd**

<b>Type of Protection</b>	<b>Pros</b>	<b>Cons</b>	<b>Cost for 3 ft. x 4 ft. window</b>
<b>Colonial Shutters</b>	Easily deployed. Good protection. Esthetically pleasing.	May need homeowner association approval. Requires room along side of window for shutter to swing out.	\$450-\$600
<b>Plastic Honeycomb</b>	Strong system. Lightweight. Reasonable cost. Won't warp or rot.	Storage of panels. Time to create and install. While cost is reasonable, still most expensive of deployable systems. Materials difficult to obtain.	\$150-\$250
<b>Storm Panels</b>	Strong. Removable. Relatively inexpensive permanent shutter system. Good protection for the costs.	Requires adequate space to store panels.	\$144 to \$168
<b>Hurricane Mesh</b>	Covers large areas and windows with unusual configurations. Allows light in. Lightweight.	Need proper supporting locations to fasten geotextile or mesh. Need accessible roofline.	\$144
<b>Plywood</b>	Materials readily available. Easy to install on lower levels.	Not as strong as some other shutter systems (for example, roll-downs, or storm panels). Difficult to install on upper levels.	\$25 to \$35 for materials only

# INSTALLING PLYWOOD SHUTTERS

Although you can install plywood shutters yourself to save on cost, you should still seek the advice of a licensed architect or structural engineer before you start. Professionals can guide you on specific details for your house's windows. The samples provided in this section may pertain to general applications, but remember that each window can be a little different. In addition, this section does not cover difficult applications such as installation for circular or triangular windows. Some insurance companies that offer discounts on typhoon insurance premiums for window coverings do not require the drawings.

## Material to Use

For plywood shutters, the National Institute for Business and Home Safety recommends that you use at least  $\frac{5}{8}$  inch plywood. Buy thinner plywood if you cannot handle the weight and your alternative is to do nothing. Thinner plywood is not as strong as  $\frac{5}{8}$  inch thick plywood and did not perform as well during destructive Typhoon Andrew in Florida in 1992. Some insurance companies may allow use of thinner  $\frac{1}{2}$  inch plywood to obtain a discount on typhoon insurance premiums. Nominal  $\frac{1}{2}$  inch or  $\frac{7}{16}$  inch is allowed under the 2009 International Building Code (IBC).

You may want to consider thicker widths such as  $\frac{3}{4}$  inch, since it is stronger than  $\frac{5}{8}$  inch. The major concern with the thicker plywood is the added weight and difficulty in handling. For most people,  $\frac{5}{8}$  inch exterior grade plywood is a good compromise between strength and practicality during installation. Plywood that is  $\frac{7}{16}$  inch is typically used for new houses, it is also recommended for existing houses, although  $\frac{5}{8}$  inch is the preference because it is stronger.

Your plywood should be treated to prevent termite damage when it is stored. In the past, harmful chemicals were used to treat plywood, but since the mid 1990s, plywood has been treated with borate, which is user-friendly and requires no special handling precautions. Thus, there is no downside to handling the treated wood currently on the market.

If you buy your plywood during the typhoon off-season, supply will be plentiful and the stores may even cut the wood for little-to-no extra charge. If you wait until a storm is approaching, there will be long lines, limited or no supply, and possibly no cutting service.

For the installation, you will need:

- A hammer
- Duplex or double-headed nails
- Circular saw
- Jigsaw
- Power drill with the proper bits



- Straight edge
- Tape measure
- Correct fasteners

### **Measuring Your Windows and Cutting the Plywood**

When you measure your windows, it is important to have a sufficient overlap of 4 inches on each side of the window.

The overlap of the windows is essential because you will be putting the fasteners that attach the plywood:

- Away from the edge of the window
- Away from the edge of the plywood
- Directly into the wall studs that surround the window rather than in the siding of the house (see Figure 2.21)

Plywood comes in 4x8 foot sheets (48 inches by 96 inches). If you need a covering that is 54 inches by 54 inches, you will need to join two sheets of plywood together. The point where two panels meet is called a joint. These joints should be supported and can be connected by 2x4's (see Figure 2.27).

It may take up to two days to measure the windows, buy the plywood, cut it to the proper dimensions, label the panels, and designate where all the fasteners are to be attached. This would be extremely difficult to do when there is an incoming storm. These preparations need to be done in advance.

### **Fasteners and Attaching the Panels**

There are many different ways to attach plywood panels to the window frame. Some literature suggests using nails in an emergency. However, nails would not be as strong as screws and also are very difficult to remove after they are attached. The following can be utilized for wood-frame houses:

- #8 wood screws with 2-inch embedment placed 16 inches apart for panel spans under 4 feet; 9 inches apart for panels between 4 feet and 6 feet; and 6 inches apart for panels between 6 feet and 8 feet; or you can use
- #10 wood screws with 2-inch embedment placed 16 inches apart for panel spans under 4 feet; 12 inches apart for panels between 4 feet to 6 feet; and 9 inches apart for panels between 6 feet and 8 feet; or you can use
- ¼ inch lag screw with 2-inch embedment placed 16 inches apart for all panel spans up to 8 feet

Figure 2.23 shows examples of the #8 wood screws (A), #10 wood screws (B), and ¼ inch lag screws (C). The duplex or two-headed nail (D) is also shown; this is used to quickly attach the panel to the frame before using one of the wood screws.

Thus, D would be used with either A, B, or C. The screws discussed in A, B, or C are self driving and should require no pre-drilling. For installation on

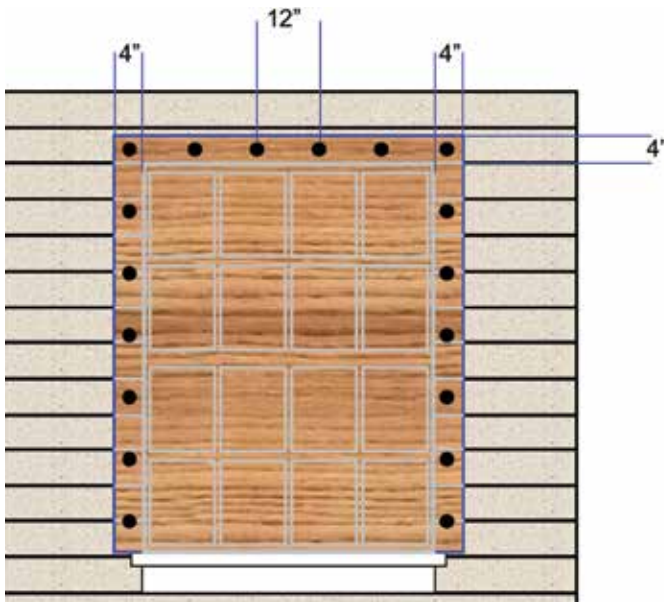

Figure 2.21. In general, a plywood shutter should have 4 inches of overlap on each side of the window. Thus if a window is 46 inches wide, the shutter should be 54 inches wide. It is important to consider the location of rebar posts in the frame of the home. Rebar may complicate the installation of screws. Source: Department of Emergency Management City and County of Honolulu.



Figure 2.22. For this double-wall house under construction, two 2x4s frame the window. When attaching the plywood to the window, the fasteners should go into the 2x4s, not the siding. It is always useful to know how your house was built. Take pictures during construction. Review your blueprints and drill small test holes if you have to. Source: University of Hawaii Sea Grant.

cement structures, pre-drilling may be useful. They can be attached quickly. All should be readily available at a hardware or home improvement store.

### **Putting the Plywood Up**

If the plywood is:

1. Precut,
2. Prelabeled, and
3. Premarked with the location of all fasteners, then deploying and installing them can be relatively quick.

First, align the panel, and then hammer a duplex nail into each top corner of the panel to hold it onto the frame. With the panel held by the two duplex nails, your hands are now free to drill the self-driving screws into the appropriate premarked location for the remainder of the panel. The duplex nail can easily be removed later, as they are designed for easy insertion and removal. The duplex nails are only used to hold the panel in place while the wood screws are screwed into place. They are not to be used to fasten the panel itself.

It is very important that you test the deployment and fasteners well before a storm. This will allow you to catch and remedy any unforeseen difficulties. For example:

- Do the screws drive in easily without pre-drilling? If not, consider pre-drilling, which is relatively quick. It is possible for one person to pre-drill with a bit and another to drive in the screws.

- Do the screws strip? Obtain high quality wood screws and, if necessary, pre-drill. Buying good screws will reduce the time of installation.
- Does your hand drill have enough torque, or does it run out of power easily? Consider an 18-volt drill instead of a 12- or 14-volt one. Have extra charged batteries and an extra charger. Also consider using corded power equipment.

Many of these questions can be answered by sales assistants at your hardware or home improvement store.

### **Disadvantages of Plywood**

The disadvantages of plywood are that it can rot or warp if stored in a wet or warm area. It is also prone to termites. In addition, plywood shutters are relatively heavy. You will need two people who can lift 30–40 pounds to help with the preparation and installation of these shutters. Plan accordingly, as it will not help if the people you are counting on to assist you are not available during the deployment. Because of their weight, it would be difficult, or even dangerous, to install plywood shutters if a ladder is needed. Thus, plywood shutters are good for easily accessible windows on the first floor, or windows that can be easily reached by a terrace or patio on upper floors.

Because financial cost is a barrier to some homeowners obtaining window



Figure 2.23. Key materials for fastening plywood panels include (A,B) 3 inch wood driving screws that allow a 2 inch embedment, (C) ¼ lag screw that is three inches long, (D) duplex or two-headed 2-inch nail. Source: University of Hawaii Sea Grant.

protection, plywood shutters are a very attractive option. Yet these shutters take time to create and deploy. Some suggestions summarized here could reduce installation time and make this option even more attractive. Some of the tips provided in this section can also apply to the installation of plastic honeycomb panels.

### **Other Methods of Installation**

It is also possible to permanently attach the fasteners to the frame of the house (see Figure 2.24 and 2.25). This has the advantage that the panels can be more quickly deployed and redeployed without drilling more holes. Attaching the fasteners permanently takes more installation time and many of the materials are not readily available. This method is useful if the panels need to be taken up and down frequently. Permanently installing the fasteners is

more complicated, and either a licensed contractor or you can do this. You will, however, need some guidance from a licensed architect or engineer. One of the difficulties in permanently installing fasteners is obtaining the materials. You can look online for typhoon shutter kits with hanger bolts, or seek assistance from a licensed contractor experienced in this area.

### **Putting up Shutters on a Concrete Building**

If the screws in Figure 2.23 (#8, #10 or ¼ lag screw) are used for masonry or concrete, they must be attached using vibration-resistant anchors with a minimum withdrawal of 500 pounds. The Simpson Strong-Tie self-driving screws are not suitable for masonry; tap cons or Simpson Strong-Tie screws can be used instead.

### **Larger Windows**

Occasionally, more than one sheet of plywood may be needed to cover a larger window or surface, like a sliding glass door. Other times, you may have two scraps of plywood that can be used to cover one window. If two sheets are joined, they should be supported with a 2x4 that joins the two pieces. Supporting all joints is stronger and can be done with a 2x4. In no case should panels be joined that results in a span of greater than 8 feet. The International Building Code and International Residential Code apply to spans up to a maximum of 8 feet.

For more information on typhoon shutter design using plywood, see: <http://www.apawood.org>.

The methods discussed in this handbook are not the only ways to attach panels. The larger your window, the more plywood will flex under typhoon conditions. Thus, you should leave a 4-inch space between the plywood and the window. If there is not enough space, the window may crack, although the plywood would stay in place and continue to serve as a wind and rain resistant envelope. One way to get around this is to build 2x4 trim around the window frame and add stiffeners. This may take considerable time and very few window protection installers or homeowners do this. However, if you prefer to do this, see: <http://www.apawood.org>.

If there is a typhoon strong enough to flex the plywood panel, then replacing your windows after a typhoon would be a relatively minor task if that is all the damage incurred. Note that during a typhoon, impact-resistant glass and laminated glass would be expected to break, even though the building envelope would stay intact if the glass attachment to the frame and the frame are strong enough. Thus these systems offer protection to the building envelope, although you must accept that the glass may need replacement after a typhoon.

Finally, whenever sliding glass doors or other entry areas are protected, it is necessary to make sure that there are always two storm-protected doors that will be operable for access and exiting at any time.



Figure 2.24. Key materials for fastening plywood panels include (A,B) 3 inch wood driving screws that allow a 2-inch embedment, (C) 1/4 lag screw that is three inches long, (D) duplex or two-headed 2-inch nail. Source: University of Hawaii Sea Grant.



Figure 2.25. Another method uses brass grommets screwed into the wood frame. A wide head screw attaches the panels. The lower screw and washer wing nut are used to hold the top two corners. Source: University of Hawaii Sea Grant.

# OVERVIEW OF WIND RESISTIVE DEVICES

## Roof-to-Wall Connection

Concepts regarding the roof-to-wall connection were covered in Figure 2.8 to Figure 2.20. In addition to hurricane clips, the rafters at gable end eaves should be strapped down. Exterior beams supported by corner columns also require strap down. For houses with post and beam roof construction, fasteners should be for roof rafter to roof beams, top of post to horizontal ridge beam, and post to beam connections located at the exterior wall (see Figure 2.8).

You should seek a licensed architect, structural engineer, or contractor to select the proper connectors and nails for your house. You can then do either all or part of this work yourself, or hire a licensed contractor.



Figure 2.26. The joint between the plywood is short, for example 4 feet to 5 feet in length, a 2x4 can be used with the wide end on the outside against the plywood. Both ends of the 2x4 are then attached with screws through the plywood and into the window frame. This will require two 4 inch or 4.5 inch lag screws which may require pre-drilling. Source: Figures 2.26- 2.29, University of Hawaii Sea Grant.



Figure 2.27. For larger windows, such as this sliding glass door, two 2x4s face outside and then are oriented with the narrow end against the plywood. The fastening screws attach from the plywood into the 2x4.



Figure 2.28. During the assembly of the larger shutters like those used on a sliding glass door, the two panels to be joined sit atop 2x4s. The outline of the 2x4s and all screw locations are marked on the panel. Panels should be cut, labeled and marked as to all fastening locations before a typhoon is on the way. The panels can be quickly attached with wood screws drilled from the plywood panel into the 2x4. The panel is then lifted up and attached to the structural frame of the window.



Figure 2.29. Vertical braces, like these, can be deployed during high wind events to strengthen the garage door. The braces are secured from the header over the garage door to the fastener installed in the concrete floor. Deployment and breakdown are about ten minutes each. The windows have been covered with a laminate film.

## Roofing

The wind from a typhoon attacks any weaknesses in the roof. Once a weakness is exposed, adjacent areas can be more easily damaged and peeled away. Thus, strengthening the roof is important and it should be considered for new construction and when a roof is replaced after its expected life.

The roofing option involves installing a continuous structural sheathing (for example, plywood where it is missing or damaged. Additional fasteners and a secondary waterproof membrane are required. You should seek a licensed roofing contractor to do this work. See also two FEMA reports: Home Builder's Guide to Coastal Construction (publication number FEMA P-499, 2010) (fact sheets 7.1 through 7.6 on roofing) and Wind Retrofit Guide for Residential Buildings (publication number FEMA P-804, 2010). If reroofing is unlikely to take place in the near future, existing older roofs can still be strengthened with spray polyurethane foam.

## Exterior Opening Protection

Exterior opening protection includes work to protect your windows, doors, and garage. This is to maintain the wind- and rain- resistant envelope of your house.

Another form of exterior opening protection includes strengthening your garage, which includes the garage door, garage windows, and the entry door. The garage door is a significant weakness during a typhoon due to its large area and the stress it is subject to. Garage door options include:

- Replacement with a stronger door
- Horizontal bracing
- Vertical bracing
- Other types of a bracing kit. For many garage doors the vertical bracing is a popular and reasonably priced option (see Figure 2.29)

More information on the design of new garage doors or retrofitting existing ones can be obtained in FEMA's Home Builder's Guide to Coastal Construction found at <http://www.fema.gov/library/viewRecord.do?id=3647> and the report Protecting Your Property from High Winds (2011) at <http://www.fema.gov/library/viewRecord.do?id=3263>.

A garage door should meet the design wind speed requirements for the area or be retrofitted to withstand the design wind speed. However, because of structural limitations in the original door, this may not always be possible.



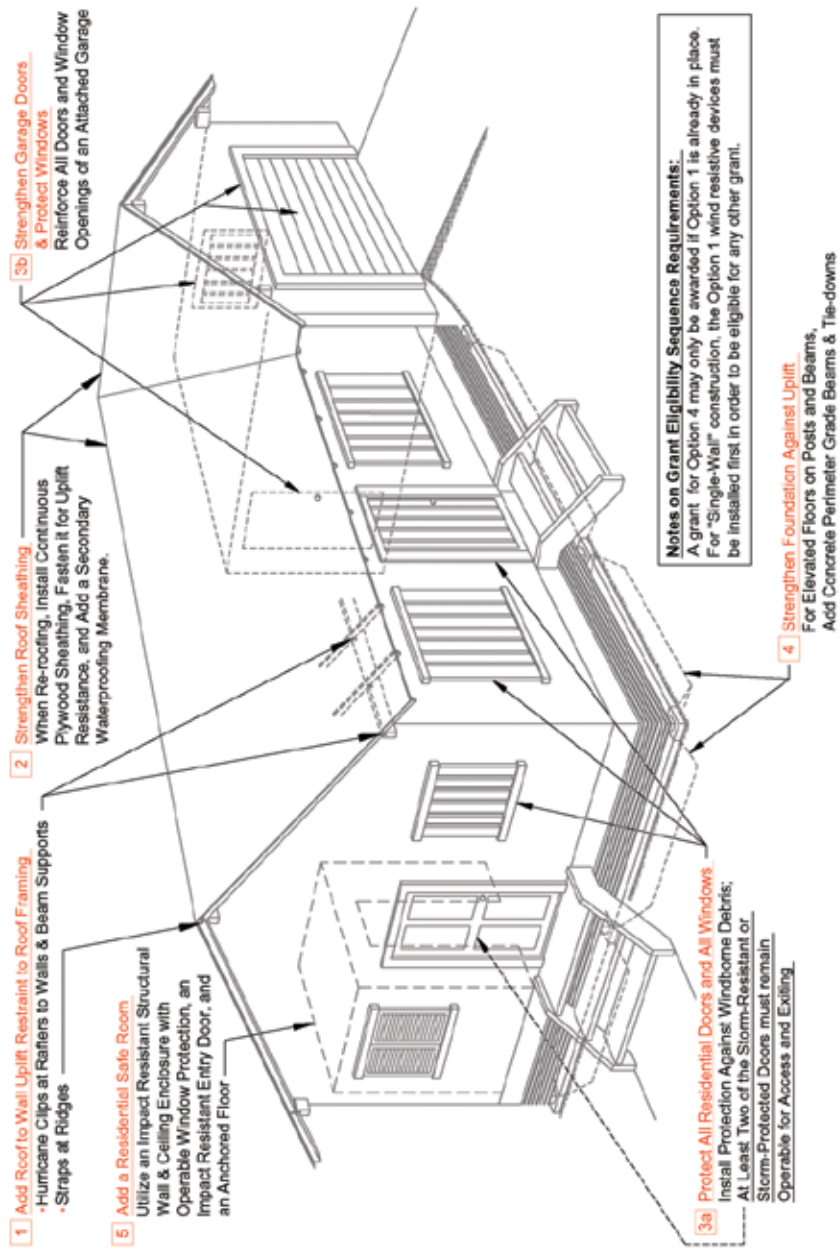

## OVERVIEW OF THE FIVE OPTIONS OF WIND RESISTIVE DEVICES ELIGIBLE FOR THE STATE LOSS MITIGATION GRANT PROGRAM

Figure 2.30. Overview of wind resistive devices. Source: State of Hawaii Loss Mitigation Grant Program.

Double entry doors should have slide bolts at the top header and bottom threshold of the inactive door, a dead bolt with at least 1-inch throw length between each door, and three hinges for each door. This requirement is similar to other guidelines for single entry doors, which call for at least three hinges and a bolt long enough that goes into the 2x4 framing of the door. Whenever entry doors are fortified, at least two of them must be operable for access and exiting at any time.

### **Foundation Uplift Strengthening Restraint**

Roof-to-wall connection is the most critical component for strengthening and completing the continuous load path connection. Once the “weakest link” has been taken care of with hurricane clips, the foundation connection can be addressed.

New houses have the complete load path connection. For older houses, it is possible to retrofit to add components of the connection. Each house is different but, in general, it will be easier and less expensive to put in hurricane clips than to do the foundation connection. Check with a licensed architect, structural engineer, or contractor to determine what is feasible for your house. In some cases, if you are willing to spend the time and have proper direction from a licensed structural engineer or architect, you may be able to properly install the

hurricane clips yourself. See the step-by-step guide for installing hurricane clips earlier in this chapter.

It is preferable to do both the roof-to-wall connection and the wall-to-foundation connection. However, if the wall-to-foundation connection is too difficult or expensive because of the way your house was built, installing only the roof-to-wall connection is better than doing nothing. Remember, the weakest link for many homes is the roof-to-wall connection and thus the hurricane clips will make that weakest link significantly stronger.

It is possible in many older houses to strengthen certain portions of the structure by attempting to complete the continuous load path connection. In particular, the “weakest link” in most houses, the roof-to-wall connection, can be fortified with hurricane clips (see Figure 2.9). You can install the hurricane clips after consultation with a licensed structural engineer or architect, or you can hire a licensed contractor who has experience in this area of work. Other portions of this work, unrelated to the hurricane clips, will most often require the work of a licensed contractor. There are financial incentives offered by some insurance carriers, to perform this work. You must follow certain guidelines to be eligible.

You should consult with a licensed structural engineer or architect if your house is being retrofitted, even if you perform some of this work yourself. The structural engineer can go over the cost and benefits of installing the following (see pages 36-45):

- Roof-to-wall connections;
- Wall-to-foundation connections;
- Stronger connectors than those required in the current building code; or
- Using connectors to transfer the load path around windows and doors. The more connections that tie the roof to the foundation the better, but the connections around windows and doors are sometimes incomplete (see FEMA documents - Home Builder's Guide to Coastal Construction P-499 and Local Officials Guide for Coastal Construction P-762).

Creating the Continuous Load Path Connection and tying your roof to the wall with hurricane clips to significantly reduce the risk of structural failure to your house.

The simplest installation is to add hurricane clips such as Simpson-Strong Tie H2.5 or H3 between the roof rafters and wall.

Adding hurricane clips to tie the roof to the walls provides significant protection. The homeowner can then attempt to complete the continuous load path connection on single-wall houses by tying the wall to the

foundation. Historically, this retrofit has been difficult due to the costs and extent of work. Recent reports, however, indicate the homeowner can more easily perform retrofit of the wall-to-foundation connection and provide significant, although not complete protection.

While the major emphasis for an earthquake is horizontal or lateral loads from shaking of the ground, often a retrofit for lateral loads, such as anchorage of the foundation posts, will also be effective in resisting vertical uplift loads caused by typhoon strength winds.

Once anchorage to the foundation posts is performed, the weight of the house itself will provide some vertical uplift protection. The key is to keep the foundation posts properly anchored with the easier to do seismic retrofit. A licensed professional structural engineer should be consulted to provide the costs and benefits of utilizing either the typhoon retrofit design for wall-to-foundation connection in the WRD technical specification or the seismic retrofit designs for wall-to-foundation connection in the post and pier report. In some cases, the homeowner may be able to do the easier seismic retrofit and still provide more lateral and vertical protection from typhoon winds than if the retrofit was not performed at all.

Additional information on the seismic retrofit is found in an online tutorial that guides the user through the retrofit process with a step-by-step questionnaire at: [http://www.hilo.hawaii.edu/~nathazexpert/expertsystem/flash\\_path\\_fix.php](http://www.hilo.hawaii.edu/~nathazexpert/expertsystem/flash_path_fix.php). The tutorial then provides design plans based on the answers provided by the homeowner.

With the addition of the hurricane clip and the wall-to-foundation improvements in this section, many existing houses can be significantly strengthened by completing as much as reasonably possible the continuous load path connection.

## PROTECTION WITH INSURANCE

### **Does Your Insurance Cover Hazards**

Typically typhoon, flood, earthquake or tsunami coverage is not included in insurance policies. Many companies provide them as options, but you must specify the additional coverage and additional premiums to your plan in advance of the hazard occurring.

Consider work to strengthen your home as a home improvement that adds value and longevity to your house while protecting your family and offering peace of mind. With a home

improvement or home equity loan to pay for the work, you may be able to get:

- Discounts on typhoon insurance premiums
- A lower interest rate because your house is used as collateral
- Tax deduction on the interest (check with your accountant)

### **Protecting with Insurance**

There are two ways to protect your property from natural hazards. The proactive way is to strengthen your house to address the individual hazard. If, however, there is still damage, insurance can provide resources to aid recovery.

Insurance is important for all residents of Guam and is a requirement for bank loans. Flood insurance is important for those in a high risk flood zone, or if you are subject to periodic flooding, even if you are outside a high risk flood zone. Earthquake insurance may not be available or can be very expensive.

### **Typhoon Insurance**

To protect your property from the winds of a typhoon, you need typhoon insurance. A regular homeowner's policy may not cover typhoons. Coverage is typically provided in terms of replacement costs, or the cost to rebuild your house. The homeowner typically selects a deductible, for example 1–2 % of the cost to rebuild. In many cases, typhoon insurance can be added to a policy at any time, unless

a typhoon is predicted to strike within 72 hours.

In Guam, some homeowners do not have typhoon insurance, particularly those without a mortgage. For homes without typhoon insurance, it is even more important to strengthen the house or there could be a major loss during a typhoon. Ideally, you would have both a strong house and comprehensive insurance.

Typhoon insurance policies vary for each company. Check with your agent and policy for the following:

- An inflation guard that increases each year as the cost to rebuild goes up? Construction costs have steadily increased and may increase even more so after a natural disaster.
- After a typhoon, there can be widespread damage and very few contractors or supplies available to perform repairs. After Typhoon Pongsona, it took more than two years for homeowners to repair their homes because of the heavy demand. This surge can result in an increase in cost to rebuild. Some homeowners have chosen to increase their insurance coverage by 30–40% to account for an expected spike in future construction costs after a typhoon.
- Additions or improvements to your house made since your initial policy purchase may not be covered, so it is important to have a periodic

appraisal so that your coverage is adequate.

- Check with your insurance agent. Not all companies provide discounts for typhoon protective devices. These discounts over time can pay for the cost of certain retrofit upgrades.
- Understand your policy. Many policies cover only typhoons and not lesser events such as a tropical storm or a tropical depression.
- Make sure you have coverage for: your main structure, any detached structures, garden or landscaping, the contents in your house, and expenses for loss of use (such as hotel stays). Only the first item is required by the banks, so you may not have sufficient coverage for the remaining items.

### **Flood Insurance**

To obtain coverage from flooding, you need flood insurance. Typhoon insurance generally will not cover floods unless wind damage from a typhoon leads to rainfall intrusion and subsequent water entering the house. However, check your policy to be certain.

Flood insurance will cover inundation or flooding for homes near a river, stream, or along the coastline. In addition, mudflows (defined as movement of the land by viscous water saturated soil) may be covered, but landslides are not (for example,

movement of the land by earthquakes). Coastal flooding and flooding from high surf, typhoon, and tsunami inundation are typically covered. Consider flood insurance if you are at risk of flooding. Insurance can be obtained even if you are not in a high risk flood zone. Check FEMA's Flood Map portal at: <https://msc.fema.gov/portal> (see Figure 2.32). Type Guam or CNMI into the search bar and hit enter. Zoom in to Guam or CNMI and navigate to the region of the island you want to analyze. Flood maps (as of 2007) are available.

### Earthquake Insurance

To obtain protection from earthquakes, you will need earthquake insurance. Homeowner's policies do not typically cover earthquakes and it can be very expensive. Earthquake insurance is commonly offered with a high deductible.

If earthquake insurance cannot be provided, it is even more important that you take steps to strengthen your house and protect the contents from ground shaking. Note that if your house is built to modern standards with a typhoon protection system (i.e., continuous load path connection), this may offer some protection from earthquake shaking.

Thus, strengthening your house for a typhoon also offers protection from an earthquake. This provides additional incentive for homeowners to act,



Figure 2.32. Flood maps are available for the Mariana Islands. Source: FEMA.



Figure 2.33. Flood insurance rate map (FIRM) of SongSong village in Rota. Insurance companies use the FIRMs to determine flood insurance rates for homeowners. Source: FEMA.

particularly if you live in a high-risk area and cannot obtain earthquake insurance.

### **Insurance for Disaster Victims**

Typhoon damage is sometimes covered under homeowner's insurance policies. But, it is a good idea to check with your insurance agent before a typhoon to make sure.

Ensure that your policy covers:

- Your house, rental units that are part of the building and any attachments to the building, such as the garage.
- Structures on the grounds that are not attached to the house, such as a pool, gazebo, tool shed, etc. This also includes the lawn, trees and shrubs on the property.

- Vacant land you own or rent, with the exception of farmland.
- Cemetery plots or burial vaults you may own.
- Personal possessions, including those of members of your household and guests, and contents of the house. This does not include the possessions of tenants in your home.
- Any items that have been loaned to you, or given for safe keeping.
- Living expense if your home is unlivable due to damage.
- Rental payments, if you rent one part of your house but it is unlivable due to damage.
- Responsibility for unauthorized use of your credit cards, forged checks or counterfeit currency accepted in good faith.
- Settlement, medical expenses and court costs brought against you for bodily injury of others or damage to the property of others.
- Most homeowners' policies DO NOT cover loss due to flooding. Check the flood maps detailed on page 65.

Language pertaining to these items should be stated in the written policy. Verbal consultation with your agent is acceptable for clarification, however ensure that the written policy reflects all terms. If it does not, request that it be updated.

Some helpful agencies' programs include:

- The American Red Cross, which

grants assistance for immediate building repairs and living expenses for groceries, new clothes and medical needs when no other immediate assistance is available.

- Federal Crop Insurance Corporation (FCIC) where farmers can insure some crops for 50, 65 or 75 percent of yield. Unavoidable losses due to any adverse weather conditions including typhoon winds are covered. Unavoidable losses due to insect infestations, plant diseases, floods, fires and earthquakes also are covered. You must have this insurance prior to the disaster.
- Small Business Administration (SBA), which offers medium and long-term loans, with moderate interest rates to qualified individuals for rehabilitation of non-farm homes and small businesses.
- Commercial and federal land banks, which offer loans with moderately low interest rates for home repairs, improvements, land equipment and livestock.
- Insurance companies, which offer long-term loans at relatively low interest rates for home repair, improvements, land equipment and livestock.
- The U.S. Federal Emergency Management Agency (FEMA), responds to major disasters and emergencies by offering financial assistance in the form of grants and loans for families, businesses and farms for loss that is not covered by

insurance. It offers public assistance to repair civic infrastructure such as roads sewers, hospitals, etc. Also, the agency offers temporary housing assistance for up to 18 months and unemployment assistance for up to 26 weeks for anyone who is jobless as a result of layoffs caused by the typhoon.

Assistance may also be available through a variety of local agencies and volunteer groups. Listen to your battery operated radio after a disaster for information on disaster relief services and locations.

### **Filing Insurance Claims**

The following steps should be taken to file an insurance claim for typhoon damage to your home:

- Call the insurance adjuster immediately. Most insurance companies will not accept claims after 60 days unless there is an extenuating circumstance, such as a property owner being off island. It's important to follow up on your call with a letter detailing the problem. Keep a copy of the letter.
- Begin cleanup and salvage work as soon as possible. Don't wait for an adjuster. Take photos BEFORE any cleanup for use as an inventory.
- Make a list of damaged articles and their costs. Receipts for these damaged items will be very helpful and useful. Provide any other information the adjuster requests to





Figure 2.31. Residents apply for disaster assistance at the FEMA/Guam Recovery Center due to damages incurred by Super typhoon Ponsona. Source: FEMA.

- process your claim. Prepare a copy of all information delivered to the insurance company.
- Keep damaged materials for proof of loss.
  - Leave a phone number where you can be reached when the adjuster arrives. The adjuster will assess damages to the house.
  - The owner has to sign proof of loss statement. Additional damage can be included when found. Payment can't be made until the insurance company sends someone to evaluate the damage. However, given the number of claims being filed, the process could take weeks or months.
  - If looting should occur, report any theft to the police.
  - Protect your property from further damage by making temporary repairs. Save receipts for reimbursement. If your home is uninhabitable, save all receipts related to your temporary lodging and food.
  - Review the settlement steps outlined in your policy. If you're dissatisfied with the proposed settlement offer, explain your position. If there's a significant difference between what the insurance company offers and what you believe you're entitled to, you may submit the dispute to arbitration.

- Some policies impose time limits such as three, six or nine months. Other policies pay the difference between normal living expenses and the cost of living elsewhere.

### **Assessing Landscape Tree Loss**

Along with assessing structural damage, property owners may need to calculate the loss of trees and other landscaping plants.

Some factors help to determine the value of the damaged landscape, including the decrease in the fair market value of the property. That can be calculated in two ways:

- Have appraisals done before and immediately after the hazard event
- Deduct the costs associated with clean up, repair or replacement from the before-hazard fair market value

Appraisals are the best proof of a decrease in fair market value. Appraisal fees are deductible under expenses incurred to determine tax liability, but are not calculated as part of the casualty loss.

- The adjusted basis of the property
- The amount of insurance or other compensation received

Cleanup, repair and replacement costs on damaged landscape may be used to measure the decrease in property value if the:

- Repairs are necessary to restore the

- property to its pre-hazard condition
- Amount spent on repairs is not excessive
- Replacement or repairs do no more than take care of the damage sustained
- Value of the property after the repairs does not, as a result of the repairs, exceed the value of the property before the typhoon

Homeowners who sustain significant damage to landscape trees may wish to contact the IRS to determine what other methods are currently being used to evaluate tree value. If homeowners decide to pursue claims or deductions, they must prove that loss was due to the hazard and that the amounts claimed as a loss are deductible. Such record-keeping also is important in substantiating any claims for loss recovery.

Some tips that can be useful in assessing landscape tree loss:

- Photographs of the property before and after the damage to show the condition and value of the property prior to the typhoon
- Newspaper articles, complete with dates can serve as evidence of the typhoon and its time and location
- Appraisals for establishing values before and after the typhoon
- Keeping receipts to support claims for repair and replacement

### **Contracts**

If your property suffers substantial

damage, you may need to hire someone to make the necessary repairs. When doing this, hold on to your money until it has been completely earned by the person you have hired to do the job. Even under critical emergency conditions, complete, good quality repairs must be done or damage and deterioration will appear at a future date. Strengthen the patches and wait patiently until you can be sure of a good job. Then, start with a clear and complete contract. Contracts are the best way to handle matters.

A contract is a promise or set of promises for which the law gives a remedy in case of breach; or, the law, in some way, recognizes their performance as a duty.

What to do when hiring a contractor:

- Plan your project carefully.
- Provide accurate plans or drawings to the contractors.
- Shop around before hiring a contractor and get at least three written bids for a project.
- Checkout other construction projects the contractor has done.
- Ask your contractor to furnish a completion bond, which guarantees that the project will be paid for by the bond if the company fails to complete the project.
- Check with your lender for recommendations or inspections of your project.
- Ensure that the contractor obtains a building permit. All work should be

per the 2009 International Building Code or International Residential Code (or latest approved Guam Building Code).

- Request a copy of workers' compensation insurance coverage if the contractor has one or more employees on the project.
- Make sure everything you and your contractor have agreed on is in the contract.
- Make frequent inspections of the project for your files.
- Withhold payment until all building supplies used have been paid for.
- Require receipts for all materials used.
- Negotiate with the contractor if problems or disagreements occur. If negotiations fail, contact the licensing board at 671.646.7262, 671.649.9676, or 670.664.4809

What not to do when hiring a contractor:

- Don't hire an unlicensed contractor.
- Don't hire a contractor without shopping around.
- Don't act as an owner/builder unless you have experience in construction.
- Don't sign anything until you completely understand what you are signing and agree to the terms.
- Don't make any payments without the proper receipt.
- Don't make agreements with subcontractors or workers without consulting the prime contractor.

## Three Elements of a Contract

- An agreement (or an offer and acceptance) to do specific things in a specific manner. State clearly, simply and completely all that is to be done. If a beginning and finishing date are involved, state them in the body of the contract. A good item to include in a contract for home rebuilding is that materials and procedures used will be those provided for in minimum standards of the current CABO (Council of American Building Officials) Code.
- Parties involved in a contract must be at 18 years of age and mentally competent.
- Something of value, usually money, exchanges hands. Signatures of parties making the agreement and the date are essential. If money or other considerations change hands before the entire contract is completed, signed receipts should also change hands.

- Don't make payments without checking with your bank.
- Don't hesitate to ask your contractor questions.
- Don't let your payments get ahead of the contractor's completed work.
- Don't make final payment until you are satisfied with the job.

Things your contract should include:

- The name and address of the contractor.
- The approximate dates the project will commence and be completed.
- A description of the job, materials and equipment to be used and the cost of the project.
- Schedule of payments to be made.
- The fact that the contractor is

responsible for obtaining lien releases from each subcontractor as each phase of the project is completed.

- A "Notice to the Owner" regarding Guam lien laws and the rights and responsibilities of the owner.
- Description of what constitutes substantial commencement of the project.

## **The Role of Government after a Typhoon**

After a preliminary damage assessment report has been completed, the governor can request a major disaster or emergency declaration from the President. The President can issue a Declaration of Emergency to supplement the effort to save lives and protect property. The President can act only after the governor has requested a Declaration of an Emergency be issued.

A major disaster declaration may be requested by the governor to the President after a natural catastrophe occurs. Assistance is offered to both the public and private sectors. With the declaration, the FEMA has the authority to engage the services of 12 federal departments, two agencies, one commission, one corporation and one authority offering 97 different Federal assistance programs.

These programs provide many different services to help people, state, territory and local governments deal with recovery from a disaster.



# PREPARING FOR A HAZARD

## FOUR DAYS BEFORE

Emergency Kit, Food and Water .....	75
Emergency Contact Information.....	76
COR 3 Emergency Checklist (Home, Yard, Vehicles) .....	78
COR 1 Emergency Checklist .....	80
Going to a Shelter .....	82
Preparing Your Home .....	83
Medical Needs .....	83
Securing Boats.....	84
Prepare for Flooding .....	85
Securing Gardens and Farms .....	85
Getting Generators Ready .....	86
How to React During Flooding .....	87

Some disasters will give you time to prepare. Often you will know if a typhoon may be coming within three to four days. At times, officials from Homeland Security will encourage people to prepare for a disaster, even if it is not a natural occurrence. Other disasters may not give you any time to prepare, like an earthquake or tsunami.

If Homeland Security officials tell you to prepare, follow instructions and you may find the tips in this chapter helpful.

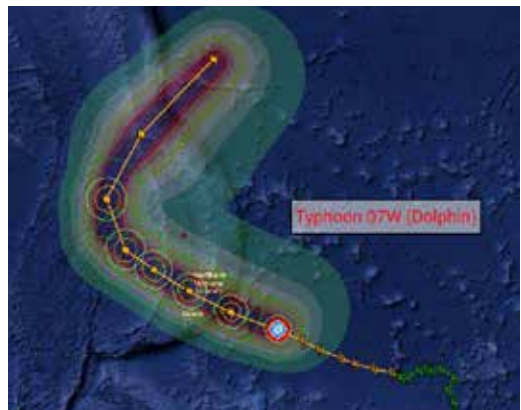

Figure 3.1. Typhoon Dolphin, 2015, tracking for the Mariana Islands.  
Source: Pacific Disaster Center.

# EMERGENCY KIT, FOOD AND WATER

Make sure the supplies in your emergency kit are fresh. Update the medical information sheets in your kit in case someone is hurt. Do you have new pets or family members in your home? Make sure they are included in your emergency kit supplies.

## Check Your Evacuation Kit

Your evacuation kit should be in an easy to find place and ready to go at any moment. Make sure every person in your family has an evacuation kit ready to go. Evacuations can require you to leave your home quickly.

Double check your bag to make sure it has the right clothing, personal hygiene items and anything else you would need for a stay away from your home. The full checklist for your evacuation bag is below in Table 3.1.

**Table 3.1. Emergency Kit Checklist**

- Two (2) copies of your family emergency plan (see page 119)
- Personal ID for all
- Cash for purchasing incidentals
- Extra copies of insurance papers, list of prescriptions, and family health records
- First aid kit and manual prescription and nonprescription medicines for at least 7 days
- Extra pair of glasses/contact lenses
- Three (3) gallons of water per person
- Seven (7) day supply of non-perishable foods
- Manual can opener
- Flashlight and extra batteries
- Candles and matches
- Multi-tool or wrench/pliers
- Personal hygiene items
- One (1) comfort item per child
- Pet supplies

### Additional Items to Consider:

- Whistle to signal for help
- Spare set of car and house keys
- Paper cups and plates and plastic utensils
- Portable gas stove with cans of fuel
- Blankets or sleeping bags
- Baby wipes and/or hand sanitizer
- Plastic trash bags
- Change of clothes and rain gear
- Sunscreen and insect repellent
- Additional play items for children
- Special items for infants
- NOAA Hand-crank Weather Radio

NOTE: FEMA recommends a three (3)-day supply of food and water, however, because of the Marianas geographic isolation it is recommended to prepare for at least seven (7) days.



**Table 3.2. Primary Radio and TV Stations**  
**These stations have partnered with the Joint Information Center to distribute information about hazards to the region.**

<b>Radio Stations</b>	
<b>Guam</b>	<b>CNMI</b>
570 AM - Newstalk57	1440 AM - KKMP
610 AM - Isla63	99.5 FM - KZGU
93.9 FM - I94	100.3 FM - KWAU
95.5 FM - KStereo	103.9 FM - KZMI
98.7 FM - Power 98	
101.9 FM	
105.1 FM - The Kat	
<b>TV Stations</b>	
8 & 11 - KUAM-TV (NBC)	<a href="http://www.kuam.com">www.kuam.com</a>
7 - KGTM-TV (ABC)	<a href="http://www.pacificnewscenter.com">www.pacificnewscenter.com</a>
See Emergency Alert System (EAS) announcements on cable stations.	

Imagine a window giving way to strong wind and rain. Then look around each room and stow any items that may be blown down, damaged or destroyed by rain water. Closets are good places for stowing items. Put important papers and documents into overhead cabinets. To prevent damage and mildew, move wicker and cloth-covered furniture into a central hallway.

As you wait for the approaching storm, imagine yourself in sudden darkness. Then arrange your flashlights, lanterns,

candles and matches in places where they can be easily found and activated. If you use candles, place them on non-flammable surfaces, such as plates, to prevent accidental fires.

It is wise to have several large sheets of plastic readily available to protect furniture and carpets in the event of water seepage, especially under and around doors. Plastic trash bags in a variety of sizes can be used to cover many different household items that could be damaged by water.

**Table 3.3. Agency Contact Information - Guam and CNMI**

Agency	Website	Phone
NOAA National Weather Service	prh.noaa.gov/guam or www.weather.gov/guam	671.472.0900
Guam Homeland Security/Office of Civil Defense (Joint Information Center)	www.guamhs.org	671. 475.9600
CNMI Homeland Security and Emergency Management	www.cnmihssem.gov.mp/	670.237.8000
Office of the Governor and Lt. Governor, CNMI	http://www.cnmihssem.gov.mp/	670.664.4550/445
U.S. Geological Survey (earthquakes)	geomag.usgs.gov/observatories/guam	804.261.2600
U.S. Geological Survey (volcanoes)	volcanoes.usgs.gov/nmi/activity/index.php	804.261.2600
Guam Power Authority	www.guampowerauthority.com	671. 475.1568
Guam Waterworks Authority	http://guamwaterworks.org	671. 647.7800
Guam Fire Department	www.gfd.guam.gov	671. 642.3534 or 911
Guam Police Department	gpd.guam.gov	671. 475.8489
Department of Public Health and Social Services	www.dphss.guam.gov	671. 735-7128/7104
Department of Agriculture /Aquatic and Wildlife Resources Territorial Veterinarian	doag.guam.gov	671. 735.3942
American Red Cross	www.redcross.com or www.redcross.com/gu/hagatna	671. 472.6217 or 670.234.3457
Guam Memorial Hospital	gmha.org	671. 647-2555 - 9
Guam Regional Medical City	www.grmc.gu	671. 645.5500
FEEMA	www.fema.gov	1.800.621.3362

## Table 3.4. COR 3 & 2 Emergency Preparation Checklist

### Home

- Have enough canned or dried food for seven days.
- Fill as many buckets, bathtub and trash cans with water as possible.
- Double-check your emergency kit.
- Put up or close shutters or other wind resistive device.
- Secure or move inside all items that might become airborne and hit your house, car or neighbors.
- Tie bikes, play equipment and lawn furniture together with rope, under the carport, to a brick wall.
- Take down canopies and poles.
- Get charcoal and propane for grills.
- Get candles and matches or lighters.
- Get medicines and prescriptions organized.
- Get the generator ready for use. Have extra fuel on hand (see page 86).
- Store clothes, blankets and pillows in plastic bags. Cover beds with plastic sheeting.
- Put sandbags under the entrances to the house where water could leak in.
- Do all the laundry.
- Raise valuable items 1-18 inches off of the ground because of possible flooding.
- Put all essential appliances and electronics on surge protectors.
- Set refrigerator and freezer to coldest setting and pack freezer with water.
- Unplug appliances you are not using to prevent damage from power outages or fluctuations.
- Remove or waterproof window air conditioners.
- Help children prepare mentally for a natural disaster.
- Avoid exiting shelter during temporary “calm” of storm’s eye.
- Don’t use generators until COR 4 has been declared after the storm.
- Call 911 for life threatening emergencies.
- After the winds have passed remain inside until the ALL CLEAR is given.
- Conserve water. It is possible that water service may be limited for several days or weeks.
- Fill containers with water.
- Recheck manufactured home tie-downs.
- When the power goes off, turn off your main breaker. This can prevent fire.
- Secure boats.
- Crack a window on the leeward side of the structure to equalize the pressure inside the structure.
- Remove trampoline safety nets, center jumping area and put them inside. Flip pipe structure upside down.

## Table 3.4 Emergency Preparation Checklist (con't.)

### Vehicles

- Fill vehicles with gas.
- Remove any valuable items from your vehicles.

- Park your car on high ground next to a concrete wall or on a side of the house that is protected from the wind.

### Yard and Ranch

- Secure or move inside all items that might become airborne and hit your house, car or neighbors.
- Store animal feed to last at least 5 days. Wrap feed in heavy-duty plastic to keep dry. Molds and fungi easily grow on wet feed and can render it useless.
- Avoid any form of stress to the animals before and after a hazard including transporting, handling, and moving animals repeatedly.
- Postpone any forms of husbandry practices such as castrations, weaning, ear notching, debeaking and vaccinations.
- Treat drinking water for poultry with soluble antibiotics and electrolytes two days before and three days after an event. Follow appropriate withdrawal periods.
- Move livestock and poultry to a covered facility with a secure roof if possible. Young animals are likely to die when exposed to cold conditions brought by wind and rain.
- Secure any loose materials to prevent banging noises, which may further irritate the animals.

- Move all equipment indoors.
- Raise valuable items 1-18 inches off of the ground to prevent damage from flood waters.
- If substantial storm damage is anticipated, you can begin new plantings before the storm hits. If a safe area is available, seeds can be germinated in seedling trays.
- Harvest all mature vegetables & fruits and those that can be used in their green or unripe stage.
- Eggplants and peppers can be pruned to 2-4 branches and to about 1-1½ feet in height.
- If practical, lay trellised crops on the ground.
- If flooding is a concern, provide an avenue for water to drain out of the field. Avoid diverting water into the neighbor's yard or other property of significant use.
- Prune banana and papaya plants by cutting all but the three youngest, healthy leaves; cut these three leaves in half lengthwise and leave the smaller top leaves and growing tip uncut.

## Table 3.5 COR 1 Emergency Preparation Checklist

### Home

- 12 hours before landfall.
- Stay calm. STAY INDOORS.
- Do not go out on the roads. Only emergency vehicles are allowed to drive.
- Evacuate if you are asked to do so.
- If you are not advised to evacuate, stay indoors and away from windows.
- Place rags or towels around the bottom of doors and windows.
- Listen for updates from the NOAA Weather Office on radio, television and online. See the full list on page 77.
- Listen to directions given by local officials over radio and in the newspaper.
- Be prepared to evacuate, especially if you live in a non concrete home.
- Bring animals inside. Turn off main breaker for power and main line for water if told to do so.
- Keep refrigerator at coldest setting. Keep refrigerator doors closed.
- Turn propane tanks off.
- Avoid using the phone except in emergencies.
- Be aware of the calm "eye;" the storm is not over. The worst part of the storm will happen when the eye passes over and the wind comes from the opposite direction.
- Move family into a small room in the center of the building.
- Closets or hallways on the lowest level are the best choice.

## **Prepare Your Kitchen and General Food Handling Practices**

Ensure that you have enough food for one week. Dried, canned or other types of nonperishable food are the types of food you should have on hand in case of an emergency. Eat the food in your refrigerator first. If the power goes out, the food in the fridge will spoil. Use paper plates, bowls, forks, knives and spoons. Each person and pet in the home should have enough to eat for seven days. Save liquids from canned vegetables to substitute for water in cooked dishes. Juices from canned fruits can be used as a salad dressing or as a beverage.

If you have time, clean the refrigerator the day before the hazard hits to minimize odor in case the power goes off for an extended period of time. Eat or discard perishable foods that spoil rapidly. At least 12 hours before the hazard, turn your refrigerator's freezer to the coldest setting and try not to open the door. This will help the food stay frozen, seven days, at a minimum. Keep canned foods in a dry, cool place. Store boxed foods in tightly-closed metal or plastic containers. After the power outage cook and eat the most perishable foods first, such as meat, ice cream, fresh fruits and dairy products. Buy food that does not require refrigeration, such as canned and dried meats, fruits, vegetables, powdered milk and cereals. Anticipate a power outage.

## **Store Water**

Each person needs one gallon of clean water to drink and to use for washing, at a minimum per day. Pets also need water. Use trash cans, bath tubs, buckets and coolers to help hold water. If the water goes out, this water will be needed for flushing the toilet and other necessary tasks. Have enough soap and detergent available for washing hands and other tasks.

Remember to clean the containers before using them for storing drinking water. Cover the container (with a weak bleach solution) inside and let it stand for 30 minutes. Then dump the bleach solution and rinse the container with regular water. Let it dry completely before filling with water. If you notice that your stored water is cloudy or has an odor, discard it.

# GO TO A SHELTER IF YOUR HOME IS NOT SAFE

## **Best Time to Evacuate**

The best time to evacuate is as soon as the shelters open before the storm is close. If you have a thatch or tin house and/or feel uncomfortable about the structure's sturdiness, you may not want to stay there for the storm's duration. Call your mayor's office to see which public buildings will be designated as shelters (see full listing on page 122). Secure your house and belongings, then pack the necessary items you will need for an overnight stay at the local shelter. Stay there until you are informed by those in charge that it is safe to return home.

In the event that you have to go to a shelter, make sure you have the items that should be in your evacuation bag listed on page 28.

## **If You Must Evacuate for Safety**

Evacuations during a hazard may be necessary. Evacuation procedures vary by location. The amount of time you have depends on the intensity of the hazard. This means that preparation is essential since there may not be time to collect the basic necessities.

- If there is time, secure your house. Unplug appliances.
- Follow recommended evacuation routes. Do not take shortcuts; they may be blocked.
- Listen to the radio for emergency shelter information.
- Carry your family emergency supply kit.

Evacuations can last for several days. During this time you may be responsible for part or all of your own food, clothing and other supplies.

Advance planning will make evacuation procedures easier. Follow your evacuation plan that you developed in the *Make a Plan Build a Kit* section on pages 24-30. Before you leave your home, shut off electricity and water at main switches and valves. Make sure you have the tools you need to do this (usually pipe and crescent or adjustable wrenches). Check with GWA to make sure you are doing it correctly.

If you have a thatch or tin house and feel uncomfortable about the structure's sturdiness, you may not want to shelter in place.

# PREPARING YOUR HOME

See Table 3.4 on pages 78-80 for preparation details regarding securing your home. Take the following measures to prepare some more home essentials for potential moisture damage.

## **Protecting Clothing and Household Textile Products**

In Guam's humid climate, clothing should be hung on plastic or plastic-coated hangers to avoid rust and water stains. Rust stains from metal hangers are difficult, but not impossible, to remove. Lemon juice or laundry aids, such as bleaches, can be used to pretreat.

## **Prevention and Treatment of Mildew**

When power has been off for several days or weeks, mildew can appear on clothing and household fabrics. Mildew is a fungus that appears especially when exposed to damp and heat. It can permanently damage and stain most fabrics, especially, ramie, linen, and rayon. Protein fibers such as silk and wool are less likely to attract mold. To prevent mildew, it is important to keep clothing and furnishings dry. Spraying damp nylon carpeting with a household disinfectant, such as Lysol Spray will help prevent mildew from getting established. Mildew can permanently

damage and stain most textiles especially cotton.

## **MEDICAL NEEDS**

Arrange to have a one-month supply of all medications on hand. Contact your doctor or pharmacy early. Ask about how to properly store medication during a power outage, especially medication that you would normally keep in the refrigerator. Have extra prescription glasses, sunglasses and hearing aid batteries.

Expectant mothers, 36 weeks and beyond will be notified through Homeland Security announcements when they should proceed to the hospital. Call your doctor if you have questions.

If you need special assistance prior to or during the hazard contact your mayor's office. Shelter information is available through your village mayor. A list of office phone numbers is found on page 122.





Figure 3.2. Boats damaged and submerged after Supertyphoon Pongsona passed the island in December of 2002.

Source: FEMA.

## SECURING BOATS

There are many different methods for securing your boat in the event of a typhoon.

Small boats, which are defined as all boats that can be easily put on a trailer, should be taken out of the water and strapped to a secured trailer. Larger boats, up to 55 feet in length, can be moored at the Harbor of Refuge in Apra Harbor, which has the capacity to hold 50 boats.

All boats, 55 feet and larger, are ordered to go to sea as soon as Typhoon Condition 2 is announced.

Boats that are on blocks should be secured tightly. Loose items should be stowed away and secured. For sailboats, the sails should be taken off. All boats that are harbored at a marina should be tightly anchored and secured.

Check your moorings as degraded rope may pose additional risk to the security of your boat.

# PREPARE FOR FLOODING

Follow the tips in Table 3.4 and 3.5 to prepare your home for flooding hazards. If you live in an area prone to flood, take these extra precautions before heavy rains start to keep your home from flooding.

- Clear debris from gutters and downspouts.
- Anchor any fuel tanks so they do not float away.
- Raise your electrical components (switches, sockets, circuit breakers, and wiring) at least 12 inches above your home's projected flood elevation.
- Place the water heater, washer, and dryer on cement blocks at least 12 inches above the projected flood elevation.
- Move furniture, valuables, and important documents to a safe place.

# SECURING GARDENS AND FARMS

Keep supplies at hand including a shovel, saw, hammer, nails, sand, bricks or sheets of plywood. The sandbags can be used to weigh down garden structures and shore up weak/damaged banks and retaining walls. In an emergency, old pillowcases, empty compost bags or black plastic sacks can double as sandbags, and they can be filled with earth as well as sand. Don't overfill the bags, and take care when lifting.

When water levels are rising unplug all exterior electrical equipment like lighting, pumps and filters. Turn off the water supply. Weigh down manhole covers with sandbags or heavy objects. Floodwaters can move them and they become dangerous holes.

Prepare farm and ranch as advised in in Table 3.4. Take valuable machinery and other times indoors or raise them up so they do not float away. Take fuel tanks or petroleum products indoors and make sure they can't get washed away. Harvest any crops that can be ripened indoors like tomatoes.



Figure 3.3. A home in Dededo was damaged after Typhoon Paka in 1997. Source: FEMA.

## GETTING GENERATORS READY

Typhoons can terminate the island's power service for an extended period of time. The use of a portable generator can provide substitute power to a home. However, the generator must be of the right capacity to start and run desired appliances.

Generators come in various levels of power generation capacity. Most portable generators are designed to simultaneously run one or two home appliances and a few lights with the use of an appropriate extension cord. Some of the larger, more sophisticated

units can actually provide enough electricity to run all of an average home's appliances. These units can actually be hooked, with appropriate wiring and switching, into the home's electrical system for more convenient operation. However, a qualified, licensed electrician must be consulted for this type of electrical work. Unqualified, unlicensed individuals should not attempt to hook-up electrical service into a house. Serious damage to the wiring system of a house, including total destruction of the generator, as well as electrocution, can occur due to improper electrical hook-up.

# HOW TO REACT DURING FLOODING

## FROM WARNINGS TO FLOOD WATERS

### REMEMBER THE LANGUAGE

#### **Flood/Flash Flood Watch**

Flooding or flash flooding is possible in your area.

#### **Flood/Flash Flood Warning**

Flooding or flash flooding is already occurring or will occur soon in your area. When a flood or flash flood warning is issued for your area, head for higher ground and stay there.

#### **Stay informed**

Listen to area radio and television stations and a NOAA Weather Radio for possible flood warnings and reports of flooding in progress from the National Weather Service, see page 77 for details. Be prepared to evacuate at a moment's notice.

#### **During Heavy Rains**

Residents and others in low-lying areas along the shoreline should evacuate, when there are heavy rain advisories and warnings. Residents and others in low-lying or flood-prone areas should be prepared to evacuate or move to higher ground. Stay away from floodwaters.



Figure 3.4. Temporary tents were set up by FEMA after Super typhoon Pongsona passed by Guam. The storm devastated the island and destroyed numerous homes, buildings and impacted water services.  
Source: FEMA.

## Table 3.6. Responding During a Flood

- If you come upon a flowing stream where water is above your ankles, stop, turn around and go another way. Six inches of swiftly moving water can sweep you off of your feet.
- If you come upon a flooded road while driving, turn around and re-route.
- If you are caught on a flooded road and waters are rising rapidly get out of the car quickly and move to higher ground. Most cars can be swept away by less than two feet of moving water.
- Keep children out of the water.
- Be especially cautious at night when it is harder to recognize flood danger.
- Avoid going near street lights, traffic signal lights, and power lines.
- Do not carry out electrical repairs inside or outside the house.
- Vehicles on the road should reduce their speed.
- Move objects that could be washed away by the river.
- Keep the windows and doors of buildings closed.
- Do not leave vehicles in underground or basement parking areas where flooding may occur, and if you are below ground level, evacuate to a safe area.
- Children and the infirm or elderly should refrain from going outside.
- Be mindful of the risk of a landslides around the house, and prepare to take shelter.
- Do not use the beaches.
- Do not enter construction sites.
- Managers and others responsible for large construction sites, slopes, etc. should inspect safety conditions in advance.



Figure 3.5. Rains flood Tumon, Guam during Typhoon Halong. Flooding can happen very quickly and sweep people and cars away with as little as six inches of water. Additionally, driving through flooded areas could cause a vehicle to stall, cause significant damage, and put you at risk for injury. Follow the guidance in Table 3.6 to reduce your risk during a flood event. Source: FEMA.

# IF SOMEONE IS INJURED

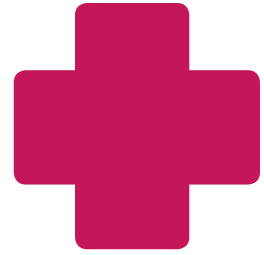

## BASIC FIRST AID

Go to a Doctor if .....	89
How to Care for Minor Wounds.....	91

---

The risk for injury during and after a typhoon and other natural hazard is high. Prompt first aid can help heal small wounds and prevent infection. Tetanus, other bacterial infections, and fungal infections are potential health threats for persons who have open wounds.

Remember, if someone is injured, evaluate before rushing in to help. If they are unconscious, make sure it is safe to go near them. Look around the area for any signs of danger like power lines, fire or things that could fall on you. Only go to an unconscious person if you are certain the area is safe and you will not become a victim. If you are not sure, call 911.

### GO TO A DOCTOR IF

- The wound has a foreign object (soil, wood, metal, or other objects) embedded in the wound;
- The wound is at special risk of infection (such as a dog bite or a puncture by a dirty object);
- An old wound shows signs of becoming infected (increased pain and soreness, swelling, redness, draining, or you develop a fever).

## Should You Call an Ambulance or Go to the Hospital?

	Yes	No
Is the person vomiting or coughing up large amounts of blood or phlegm?		
Is the vomit green, black or bloody?		
Does the victim have symptoms of dehydration like very dry mouth and armpits, confusion or decreased urination?		
Is the person dizzy or feel like they are about to faint?		
Does the person have memory loss, blurred, double vision, slurred speech or are they confused?		
Does the person have chest pains or pain in their back, jaw or left arm?		
Does the person have a rapid or very fast heart beat?		
Does the person have a fever of 100.4 °F (38° C) or above? This is especially important with children and elderly adults.		
Are they having difficulty breathing?		
Does the victim have cold, sweaty skin? Is their skin bluish or pale after being pressed?		

### **Consider Calling Your Doctor or an Ambulance If You Answered Yes to Any of the Questions Above.**

This is not a complete list. Use your best judgement. Many of these symptoms are more urgent for children or the elderly.

See a complete list of emergency numbers on page 121. Keep this check list with you to give information over the phone to the hospital.

# HOW TO CARE FOR MINOR WOUNDS

- Wash your hands thoroughly with soap and clean water if possible
- Avoid touching the wound with your fingers while treating it (if possible, use disposable, latex gloves).
- Remove obstructive jewelry and clothing from the injured body part.
- Apply direct pressure to any bleeding wound to control bleeding.
- Clean the wound after bleeding has stopped.
- Examine wounds for dirt and foreign objects.
- Gently wash the wound with bottled water or clean running water (if available, saline solution is preferred).
- Gently clean around the wound with soap and clean water.
- Pat dry and apply an adhesive bandage or dry clean cloth.
- Leave unclean wounds, bites, and punctures open. Wounds that are not cleaned correctly can trap bacteria and result in infection.
- Provide pain relievers when possible.

## **Other Considerations**

- Expect a variety of infection types from wounds exposed to standing water, sea life, and ocean water.
- Wounds in contact with soil and sand can become infected.
- Puncture wounds can carry bits of clothing and dirt into wounds and result in infection.
- Crush injuries are more likely to become infected than wounds from cuts.

## **Preventing Tetanus**

If you have wounds, double-check your tetanus immunization. If you receive a puncture wound or a wound contaminated with rust, feces, soil, or saliva, have a health care professional determine whether a tetanus booster is necessary.





# HEADING HOME AND CLEANING UP

## AFTER THE ALL CLEAR IS GIVEN

Getting Home .....	93
Recovery Checklist .....	94
Drinking Water Safety .....	96
Water for Other Uses .....	97
Food Safety .....	99
Stopping the Spread of Disease and Invasive Species .....	102
Cleaning the Ranch.....	105
Special Considerations for Flooding .....	107
Potential Hazardous Materials .....	109
Care of Soiled Clothing and Textiles .....	110
Helping Children Cope with a Disaster .....	113

### GETTING HOME

Proceed carefully after a disaster. The area may not be safe and you do not want to become a victim as you are headed home. Do not attempt to go home until you are told it is safe to do so.

If you sheltered in place, structures can still be dangerous. Ensure that gas, water, and electrical functions do not present a hazard before proceeding with any other clean up efforts (see Table 5.1).

Wait until an area is declared safe before entering. Roads may be closed because they have been damaged or are covered by water.

Barricades have been placed for your protection. If you come upon a barricade or a flooded road, go another way. Keep listening to the radio and updates from Guam Homeland Security and National Weather Service for news about what to do, where to go or places to avoid.

## Table 5.1. Hazard Recovery Checklist

After the emergency is over, call or text your family and friends to tell them you are safe.

Take photos of the damage and necessary repairs for insurance purposes.

### **If you must walk or drive in areas that have been affected:**

- Stay on firm ground. Moving water only six (6) inches deep can sweep you off your feet. Standing water may be electrically charged from underground or downed power lines.
- Identify downed power lines and do not touch them.
- Use extreme caution when entering or working in buildings - structures may have been damaged or weakened.
- Inspect your home and property for damage. Do not go in your home if it appears to have significant structural damage.
- Wear sturdy shoes when walking through broken glass or debris, and use heavy gloves when removing debris.

### **Check gas, water and electrical lines and appliances for damage.**

- Use a flashlight to inspect for damage.
- If main gas lines or electrical switches were not turned off prior to the hazard, turn them off until you have checked the structure to ensure there are no broken gas lines or electrical hazards. Have these services restored by a professional.
- Report any damage to water supply, sewer facilities, embankments, or roads by contacting the water company or your mayor.
- Notify the power or fire authorities on your island if you see fallen or damaged electrical wires.
- If any of your appliances are wet, turn off the main electrical power switch in your home before you unplug them. Dry out appliances, wall switches and sockets before you plug them in again.

### **If you smell leaking gas, turn off the main valve.**

- Do not use candles, lanterns, electrical or torches of any kind as they can cause an explosion if there is gas in the air.
- Ventilate the structure before lighting any matches or candles.

# INSPECTION AND CLEANUP

Threats of serious injury abound in the aftermath of a typhoon. The following precautionary measures are suggested when conducting initial inspection and cleanup.

Do not allow children to play around damaged structures and debris cluttered areas. Also, keep away from any and all downed power lines and report them to the power company.

## **Cleaning Damaged Structures that Are Safe to Enter**

You will most likely find a shortage of materials, so temporary repairs may require some creativity. First, clean and remove all broken glasses. Next, repair all broken windows, doors, and roofs with suitable materials like heavy plastic, canvas, Plexiglas and lumber. Covering a damaged roof is very important when you wish to avoid further water damage to furnishings and personal items, as well as to the interior structure of the house.

If your house is equipped with roof gutters and/or downspouts, inspect and clean them if clogged. You can collect rain water from your gutters/downspouts for use in cleaning activities.

Once sufficient structural repairs are made, clean and dry all furniture and other water-soaked personal items. Most home furnishing can be cleaned by wiping them down with a mild soap solution and clean water.

In case of severe flooding, sweep out all the water. Shovel out any mud that may have entered the building while it is still moist, to give floors and walls a chance to dry.

Brush off any loose dirt on smooth walls and ceilings with a mild soap solution and wipe with a damp cloth. Walls and ceilings with special surface materials may require a separate cleaning method, or major resurfacing work.

Inspect your plumbing system, especially floor drains, and remove any material causing clogs.

The heavy salt content of typhoon rain has a corroding effect on concrete, causing chipping, fragmentation or flaking. If a sufficient source of fresh water is available, rinsing the concrete surfaces will give them a longer life. Never use contaminated water for this purpose. Clean all metal structures and surfaces immediately, then wipe with a cloth soaked in kerosene. A final coating of oil should help prevent rust.

# DRINKING WATER SAFETY

Water for drinking and cooking, referred to as **potable water**, is the most essential item to have on hand during and after a hazard. Water outages during and after a hazard are common. Therefore, preparations for potable water storage and handling should begin 48 hours before the onset of the anticipated hazard.

Potable water should be stored in clean food-grade containers. Store enough water based on your estimated family needs for at least a 3-4 day period. Three (3) gallons per person per day. Smaller quantities of drinking water

can be stored in plastic containers and then frozen to help keep both your refrigerator or freezer cold and provide cold drinking water as the ice melts. Don't fill containers to the top or make sure to leave caps off as water expands when frozen.

Larger quantities of potable water can be conveniently stored in plastic garbage cans with wheels and snap-on lids. Lining garbage cans with plastic liners, such as clean plastic trash bags, helps prevent leaks. Be sure to keep stored potable water near or in the kitchen area but away from doors and passageways. In the event that no water outage is experienced during and after a typhoon, try and utilize all stored water as a public conservation measure.

## Table 5.2. Drinking Water Safety Checklist

### DO

- Listen for all public announcements about water.
- The water company will announce when and if the tap water is safe to drink and use.
- If the tap water is not safe, follow instructions on boiling the water to disinfect it for cooking, cleaning and bathing.
- Only use bottled water from a safe source. If you don't know where it came from, boil it before use. If you can't boil the water, use chlorine tablets, iodine tablets or chlorine bleach. Follow the directions for each. Using these methods will not kill all parasitic organisms.

### DO NOT

- Drink the water until you are told it is safe to do so.
- Drink cloudy water or water with an unusual odor.
- Drink water labeled as non-potable
- Use water disinfection methods that have not been recommended by GWA.

# WATER FOR OTHER USES

Conserve water during the recovery period. Postpone doing laundry for as long as possible. Do not wash cars or water lawns. Use the water from storage tanks and other containers with caution. If tanks have been contaminated with flood water you must not drink the water.

## **Water for the Bathroom**

Water for toilet and other hygienic uses is also an essential item to have on hand during and after a hazard. Since water outages during and after a hazard are not unusual, water storage for sanitation purposes should begin at

least 24 hours before the onset of the anticipated hazard event.

During a water outage, the use of only one bathroom will simplify sanitation and cleaning. Preferably, select a bathroom with a bathtub. Plug the drain of the bathtub and fill with water. If possible, store a few large containers, such as plastic garbage cans, in the bathroom and fill with water. Keep a two gallon bucket handy in the bathroom. The water in the bathtub and containers can be used to flush toilets and for showers. Store several rolls of toilet paper individually in plastic or zip lock bags to minimize moisture and accidental contact with water.

## **You can sanitize drinking water by:**

- Boiling it for 1 minute before using. Let cool and store in food grade container; or,
- Treating it with liquid chlorine bleach by using one (1) drop of bleach for a glass of water; or ten (10) drops of bleach for one gallon of water. Be sure to allow all chlorine treated water to stand 30 minutes before using. Bleach treatments do not remove all parasitic organisms like Giardia or Cryptosporidium.

If the water is cloudy or brownish with floating materials, boiling is the preferred treatment method. The chlorine bleach treatment can be used, but the above mentioned chlorine dosage must be doubled and the water must stand at least one (1) hour before using. Store all sanitized water in clean covered containers.

## Flushing Toilets

Toilets can be flushed in two different ways during a water outage.

One method involves manually pouring two to three (2-3) gallons of water into the tank of the toilet for regular flushing. The other method involves pouring at least two (2) gallons of water, in a quick manner, into the bowl. Use a wide mouth container to pour the water into the bowl almost all at once.

## Frequency of Toilet Flushing

It may be necessary to conserve water for some time, so flushing after every use will deplete your water supply. There is a saying that goes: "When it's yellow, let it mellow. When it's brown, flush it down." In other words, when the toilet is used for urine only, you may wish to flush it only after several uses. On the other hand, flush after each bowel movement.

## Used Toilet Paper

Used toilet paper requires more water and may cause blockage due to insufficient water pressure from flushing. It is advisable to place used toilet paper in a plastic or ziplock bag for disposal in the trash rather than flushing.

## Bathing

Showers can be improvised without running water. For a warm shower, place one to two (1-2) quarts of boiling water into a half-filled bucket of water. You may add more water to fill the bucket. With a plastic cup, use the warm water to first wet your hair and body before shampooing and/or soaping, and finally for rinsing off.

You can also bathe in just two gallons of water by filling a basin with water, then soaping and rinsing as you wash down your body. Refreshing mini-showers can be taken with a bar of soap during rain showers (or in rain runoff), so keep a swimsuit handy.



Figure 5.1. A porch on Guam is inundated with flood waters after heavy rains associated with Typhoon Halong in December 2014.

Source: FEMA.

# FOOD SAFETY

Food safety precautions can protect your family from unnecessary illness after a hazard. Food can become contaminated as a result of fire, flood, water and/or wind related exposure. Also, it may spoil or become unsafe after a power outage.

**If you have any doubt about the safety of any food item, throw it away.** Dispose of all foods, including sealed unopened cans, that have been covered by water suspected of containing sewage waste. Foods in sealed cans not fouled by

contaminated water are safe to eat if the cans are free from rust, have no bulges or leaks, and have been disinfected prior to opening. Commercial glass jars of food are safe if the containers have been sanitized.

To sanitize contaminated cans and glass jars, remove the labels and mark the contents on the can or jar lid with indelible ink. Wash with soapy water, immerse in a chlorine bleach solution (ten [10] drops of bleach to one gallon of water) and air dry before using. Cans, empty glass jars, metal pans and utensils may also be sanitized by boiling for at least ten (10) minutes.

## Table 5.3 Food Safety Checklist

### DO

- Throw away food that may have come in contact with flood or storm water.
- Throw away food that smells odd, looks odd, or has an odd texture.
- Throw away perishable foods (meat, poultry, fish, eggs and leftovers) that have been 40°F for two hours or more.
- Throw away canned food that is bulging opened or damaged.
- Throw away any food in a sealed jar or container that may have come into contact with floodwater. These items can't be disinfected.
- Rinse any canned food item in bleach. Remember to take labels off because they may have dangerous bacteria.

### DO NOT

- Keep or eat anything that has touched flood waters.
- Keep any perishable food that has been sitting out for longer than 2 hours.
- Throw away food that is still frozen, unless it has touched flood water.
- Use contaminated water to wash dishes, brush your teeth wash, prepare food, wash your hands, make ice or baby formula.



Generally, food in a refrigerator will be safe if the power has not been out longer than a few hours and the temperature has been at 40°F or below. Food in a full, free-standing freezer should be safe for about two (2) days if the temperature was at 40°F or below. Food in a half-full freezer should be safe for about 1 day if the temperature was at 0°F or below. Partially thawed frozen vegetables with ice crystals may be safely refrozen.

Dry ice can keep foods frozen if placed over the food on boards or heavy paper. Allot 2½-3 pounds of dry ice per cubic foot of space. More dry ice will be needed in upright freezers because the dry ice must cover every shelf. This will keep food for 2 days. Fill partially filled freezers with crumpled newspaper to reduce air currents which will dissipate dry ice. (WARNING: Dry ice can burn bare skin).

### Cooking Tips

If a typhoon has knocked out your power or gas line, cooking meals can be troublesome and hazardous. Charcoal or gas grills are obvious alternatives. To avoid the danger of fire and poisonous gases, NEVER USE THEM INDOORS. Camp stoves that use kerosene or solid (Sterno\*) fuels should always be used outdoors for the same reasons. Wood can also be used for cooking. Always build the fire outside, away from any buildings, making sure that it is well contained.

A metal drum or stones can be used to contain the fire. A charcoal grill is a good place to build a wood fire. Never use gasoline to start a fire and be sure to put out your fire.

### To Prevent Disease

- Wash all fresh food with safe drinking water before eating it.
- Cook food properly and thoroughly.
- Do not eat land crabs or shellfish from the shoreline around bays or along rivers.

Wash dishes and tableware with hot soapy water, rinse well, and sanitize by soaking the dishes for at least one minute in a solution of two tablespoons liquid chlorine bleach for every gallon of water.



Figure 5.2. A refrigerator door was ripped off from inside a home during Typhoon Paka. Strong winds can destroy homes and property during a storm. Be safe and go to a concrete home or shelter before the storm hits. Source: FEMA.

## Food Safety After a Fire

Food that has been exposed to fire can be affected by three factors:

- The heat of the fire
- Smoke fumes
- The chemicals used to fight the fire

Food in cans or jars that have been close to the heat of the fire may appear to be unharmed, but the heat from the fire can activate food spoilage bacteria, leaving them inedible.

Burning materials may release toxic fumes that contaminate food. Discard any type of food stored in permeable packaging such as cardboard or plastic wrap. Discard raw food outside the refrigerator. Food in refrigerators and freezers also may be contaminated. The seal on these appliances is not completely airtight. Discard any food with an off-flavor or smell. The chemicals used to fight fires contain toxic material that can contaminate food and cookware. Throw away foods exposed to the chemicals. Chemicals cannot be washed off the food. This includes food stored at room temperature, as well as foods stored in permeable containers such as cardboard and screw-topped jars and bottles. Sanitize canned goods and cookware in the same manner as recommended for flood damaged foods.

## Good Health Practices

To maintain your personal hygiene:

- Wash your hands with soap and water after you've touched any unclean water or debris, before you eat anything or after using the toilet.
- Use garbage cans to contain garbage and food scraps. Always keep the garbage cans covered.
- Use a clean toilet or outhouse and stay clean by bathing regularly.
- Keep a container of chlorinated water in the bathroom for washing hands. Change this water daily. When drinking, always use a clean drinking glass and be sure the water is from a safe source.
- Install screens and windows to prevent flies from entering your home.

# STOPPING THE SPREAD OF DISEASE AND INVASIVE SPECIES

In the aftermath of a hazard, there is a higher rate of diseases carried by insect pests and rodents. In addition, invasive species can easily be spread or flourish during recovery efforts.

After a hazard, insect pests, rodents and snakes may be left homeless. It is not uncommon to find these pests and animals seeking food and shelter in areas where people reside. Damaged structures, with their many accessible entrances, have a higher probability of attracting rodents and snakes.

Animals may also be found under debris scattered by the typhoon or in debris piles created during the cleanup effort. These pests are a potential health hazard.

## Preventing the Spread of Invasive Pests

- Be aware of invasive pests on or around your property.
- If there is a risk of spreading invasive pests from your property during pre and post storm clean up, please contact your local Cooperative Extension Service for technical advice on how to handle the pest.

### Invasive weeds

- Be mindful of what green waste you move on to or from your property. Invasive weeds can be spread by moving plant parts or seeds.

### Coconut Rhinoceros Beetle (CRB)- *Oryctes rhinoceros*

- Clean up and remove all green waste on and around your property to prevent creating breeding sites for the CRB.
- Any green waste left on your property should be covered with CRB tekken netting found at local hardware stores to capture any CRB.

### Little Fire Ant (LFA) - *Wasmannia auropunctata*

- If LFA is on your property, DO NOT move green waste to other sites that are LFA free.
- Contact your local Cooperative Extension Service for LFA recommendations.

## General Guidelines to

### Discourage Infestation

Remove debris from around the farm as soon as possible. Debris attracts rodents that snakes feed on. It also provides shelter for snakes. Remove potential food sources such as household trash and wasted grain. Be cautious where you place your hands and feet when removing or cleaning debris so you don't get scraped or bit by a rat or snake. Wear gloves and don't place your fingers under debris you intend to move. Wear tall boots. Watch for snakes resting on fallen trees, branches and other debris.

### Controlling Mosquitos

Dengue Fever, also known as Breakbone Fever, is caused by a virus that is transmitted by mosquitos. Take precautions, stop mosquitos from breeding by taking the following steps:

### Eliminate breeding spots:

- Empty, cover, discard or turn upside down containers that hold water, such as bottles, jars, buckets or barrels. Discard old tires at a proper dump site or store them in a shed or garage. (Any water that has collected may be polluted by flood waters and may be a health hazard, in addition to being a breeding place for insects.) Also, check clogged gutters and flat roofs which have poor drainage.
- Repair leaky pipes or outdoor faucets to prevent water from gathering into small pools or puddles.
- If you raise plants in water, change the water every 3 to 4 days. It takes a mosquito about one week to develop from a hatched egg to an adult.
- Change daily the water dishes of pets, poultry and livestock.
- Cover rain barrels and other water catchments with fine mesh screening

## If You Find a Snake

A Brown Tree Snake can be captured by pinning it down with a long stick or pole, preferably forked at one end. Stay out of the snakes striking range which is estimated to be one half the snakes length. Kill it and remove it by scooping it up with a flat-blade shovel. To kill the snake, club it with a long stick, rod or similar tool.



Source: Guampedia.

If you are unable to kill it, isolate the snake within a small area. If you are uncomfortable about removing the snake yourself, seek out someone who has experience, such as a neighbor or someone from the Division of Aquatic & Wildlife Resources, Dept. of Agriculture, see Table 3.3. Remember to stay out of the snake's striking range.

(a minimum of 18 mesh per square inch).

- Cover and drain barbecue pits.
- Remove abandoned vehicles and broken equipment, such as old washing machines, toilets or roofing tin.
- Fill in puddles or ditches that collect water.
- Containers used to collect condensation from air conditioners should be emptied at least twice a week and washed to remove mosquito eggs and larvae.
- Once a week, burn all coconut shells and any open coconuts, or turn the shells upside down.
- Clear leaves and other rubbish from roof gutters.
- Patch screens and other places where mosquitoes may enter buildings. Paint screens with an insecticide.
- Use a household spray or an aerosol bomb to kill mosquitos, flies or other insects that get into buildings. Do not apply oil-based sprays to flowers or ornamentals.
- If possible, keep small children indoors, especially in the evening. Persons who must go outside at dusk should use a repellent on exposed parts of the body and clothing.

### **Controlling Rodents**

Rats and other rodents often move into buildings to escape floodwaters. Rats and small vermin can carry disease. They should be eliminated as soon as possible. Because of the danger of rat

infestation, use caution when entering flooded buildings.

- Carry a solid club and a flashlight.
- Inspect likely hiding places for rats. Check closets, furniture, drawers, mattresses, stacks of clothes or paper, appliances, upholstered furniture, dark corners, attics and basements.
- Be extremely careful when approaching rats. A starving rat can be dangerous.
- Eliminate rat populations by poisoning rats, keep baits and poison out of the reach of children. Alternatively, consult with a pest removal company as soon as possible.
- Remove food sources. Store food supplies in rat-proof bins or containers. Suspend garbage containers from trees or posts. Remove animal carcasses which may attract rats. Do not leave scraps of food around.
- Maintain several permanent rat bait stations in strategic locations, even after rat infestation has been controlled. This should eliminate rats that can migrate from neighboring areas, and will help prevent another infestation. Inspect baits frequently and replace them with fresh material whenever necessary.
- If you are bitten by a rat, take the rat to your local health authorities or a veterinarian. The animal should be checked for rabies.

# CLEANING THE RANCH

## **Livestock**

If the roof blows away, livestock will be exposed to rain, wind, chill and cold. This may lead to health problems such as respiratory ailments, reproductive infections and diarrhea. Mature animals may withstand cold, but over-exposure can lower their resistance to infections. Younger animals will be more susceptible to disease after periods of stress.

If severe structural damage has occurred such as a blown-away roof or walls that expose animals to the cold, rain or hot sun immediate repairs should be undertaken, or temporary shelter should be provided.

Power outages can cause low water pressure or lack of water for several days or weeks. If running water is available, and if the farm is equipped with a watering system, consider applying soluble antibiotics for at least 3-5 days. Follow appropriate withdrawal periods of antibiotics. For questions contact the Territorial Veterinarian.

Delay permanent repairs until buildings are thoroughly dry. Avoid feeding wet feed to livestock unless absolutely necessary. To avoid a fire hazard, move wet hay outside and spread it out to dry. Move livestock to unflooded pastures to prevent disease. Livestock losses

should be documented and reported to the Department of Agriculture or any disaster relief agency for possible aid.

## **Disposal of Animal Carcasses**

Report any high incidence of sick and dead livestock or poultry to local or federal agriculture agency. Because the soil is relatively shallow on Guam, it is not recommended to bury dead animals to avoid soil contamination. Instead, place the carcass in a plastic bag and take it to a Transfer Station, or an area has been set aside for the disposal of carcasses. If you are not able to go to the transfer station, or it is closed, leave the carcass in the sealed plastic bag and go to the transfer station as soon as you can. The Animal Control & Quarantine Unit of the Guam Department of Agriculture, can also help in the disposal of dead animals.

In the event that an animal is injured, follow first-aid procedures for preventing shock. Call your veterinarian or the territorial veterinarian of the Dept. of Agriculture (see table 3.3).

## **Flooded Machinery**

If machinery has been flooded, thoroughly clean and service engines before starting. Take diesel engines to your dealer for inspection of fuel injection systems.

In addition:

- Drain crankcase oil and remove oil pan. Clean the inside of the engine with flushing oil or kerosene and

- change the filter.
- Remove cylinder head from engine if water has been near the level of the combustion chamber. Clean thoroughly, dry and replace.
- Lubricate rings by putting oil on the cylinder walls.
- Remove the carburetor and intake and exhaust manifolds; dry and service all distributors, generators and starters that have been under floodwater.
- Remove the fuel tank & flush clean if it has been flooded.
- If the engine heats up after starting, stop and recheck your work.

### **Typhoon Damaged Farm Implements**

Farm machinery damaged during a hazard should be promptly reconditioned. Do not start equipment, motors, or engines until they are cleaned and reconditioned both internally and externally.

Mud and silt can be removed by hosing with pressurized water. Brush with fuel oil or kerosene to lift silt deposits. For machinery that has been exposed to saltwater, over-lubricate with fresh lubricant to flush out dirt and water. Remove, clean, lubricate and replace all wheel bearings. Consider that sealed bearings might be damaged. Move the machine parts by hand to make sure all moving parts are free before applying power. Be sure they are completely dry before painting. Thoroughly clean and

dry all belts before replacing. Prevent rust on polished working parts by cleaning and applying a rust preventive coating. If a tractor has not been submerged deeper than the platform and has no water in the engine, only the wheel bearings and other submerged parts need to be serviced.

### **Special Considerations for Gardeners and Farmers**

In addition to the precautions and responses covered in the previous pages, gardeners, farmers, or homeowners may want to consider the following measures.

#### **Turf Grass Recovery**

Turf grass can be damaged by tidal surges (or by storms with little rain). Salt water can burn turf and should be irrigated as soon as possible.

Irrigation with clean, salt-free fresh water is probably the most important practice to follow when rinsing accumulated salts from turf leaf surfaces and leaching salts from root zones of soils.

Too much water increases incidence of disease. Water logged soil can also damage roots.

#### **Flooded Gardens**

If flood waters have covered a garden, some produce will be unsafe to eat. The safety of unharvested fruits and vegetables will depend on the kind of produce, the maturity of produce at

the time of flooding, if it is dry or wet season, severity of flooding (depth of the water and silt), the duration of flooding, and the bacterial content of floodwater.

In general, immature fruits and vegetables at the time of flooding should be safe to eat by the time they are ready to harvest. For additional safety, disinfect produce and cook it before eating.

Unless flooding was light and there is no danger of bacterial contamination from floodwater, do not use fruits and vegetables that were ready for harvest at the time of flooding unless they are disinfected, peeled and thoroughly cooked. Some fruits and vegetables are more susceptible than others to bacterial contamination.

- Leafy vegetables such as lettuce, cabbage, mustard, kale, spinach, celery and fleshy vegetables and berry fruits such as tomatoes, summer squash & peppers are highly susceptible to bacterial contamination.
- Silt and other contamination may be imbedded in the leaves, stems or other natural openings of fleshy structures and can be difficult to remove.
- Root, bulb and tuber crops such as carrots, radishes and onions are less susceptible to bacterial contamination. Disinfect these vegetables, peel and cook them thoroughly before eating.

- Produce with a protected fruit or impervious outer skin such as cucumbers, peas, melons, eggplant or sweet corn should be washed and disinfected before the outer shell skin or husk is removed. Then shell, peel or husk the produce and cook, if possible.

Thoroughly wash and disinfect any produce before eating.

- Wash in a strong detergent solution with a scrub brush. Remove all silt.
- Immerse produce for 15-20 minutes in a chlorine solution.
- Rinse thoroughly with safe drinking water.
- Peel, if possible, and cook thoroughly before eating.
- Refer any specific questions to Guam Department of Public Health and Human Services, see table 3.3.

## SPECIAL CONSIDERATIONS FOR FLOODING

Use extreme caution when entering any building damaged by flooding. Watch for loose plaster and ceilings that could fall. Open as many doors and windows as possible to remove moisture, odors and flammable or toxic gases. If the windows are stuck tight, take off window strips and remove entire sash. If doors are stuck, drive out door hinge pins with a screwdriver and hammer,



and remove doors.

If you are not qualified to judge the stability of a foundation, hire a contractor to make this inspection.

Examine foundations and supports for undermining. If walls or foundations have settled or cracked, uncover footings and raise, reinforce or brace any settled sections.

Be extremely careful when uncovering footings, because of the possibility of cavernous washouts.

- If underlying material has been washed away, consult an engineer for repair options.
- Check piers for settling or shifting.
- If the building has shifted or the floors have settled badly, it may be necessary to install temporary bracing until extensive work can be done.
- Drain any crawl spaces which contain water. Wash out mud, dirt and debris as soon as possible with a hose and mop, cloth or sponge. Clean walls and floors before silt or mud dries.
- Start cleaning from the top floor or upper limit of flooding and work downward toward the first floor or basement.
- Brace walls where necessary.
- To speed up drying of flooded studding and insulation, remove all siding strips or plaster from upper and lower parts of the walls.
- Do not repaint walls until they are completely dry. This may take several months. Flooded insulation may be ruined.
- Remove loose plaster. After house is completely dry, repair damaged plaster on walls and ceilings. Badly damaged plaster walls can be resurfaced with gypsum board or plywood.
- Flooded wooden floors will dry out slowly. Don't build fires to speed up their drying, as this could cause cracking or splitting from uneven drying.
- To prevent further buckling and warping, drive nails where the floor tends to lift or bulge.
- After floors are dry, level by planing or sanding.
- If floors are too badly damaged to be refinished, lay a new floor over the old, or cover with carpet, vinyl or linoleum.
- If a concrete floor is badly damaged, break it up and install a new floor. If damage is minor, patch with a rich mixture of concrete containing no coarse gravel aggregate. Use knife consistency patching compounds to repair minor leaks.

### **Hazardous Material Accidents in the Home**

Dry off containers that get wet. Move them off damp shelves until the shelf material has dried thoroughly. Check labels on wet containers and re-glue or tape them securely before they come off completely. Be aware of how different chemicals may react during mixed spills. Some common chemicals and their dangers are summarized in Table 5.4 on the next page.

## Table 5.4 Potential Hazardous Materials

Hazardous Item	Toxic	Flammable	Explosive (in fire)	Reactive
Paints	✘			
Adhesives	✘	✘		
Paint Thinner	✘	✘		
Pesticides	✘	✘		
Fertilizers	✘	✘ (most)	✘ (if mixed with gasoline)	✘
Gun Ammunition			✘	
Aerosols			✘	
Natural Gas		✘	✘	
Sewer Gases (from broken pipes)	✘		✘	
Alcohol		✘		
Nail Polish Remover		✘		
Gasoline	✘	✘		
Brake Fluid	✘	✘		
Antifreeze	✘	✘		
Oil		✘		
Transmission Fluid	✘	✘		
Cleansers				✘
Cooking Oil		✘		
Detergents				✘

# CARE OF SOILED CLOTHING AND TEXTILES

Some types of soil are soluble, while other types are insoluble. Soluble dirt can consist of organic acids, mineral acids, alkaline substances, blood, starches and sugars. All these substances dissolve in cool or warm water.

Unfortunately, when dried, they require special stain-removal techniques and extra time to remove the dried soils. Soiling should be treated immediately after the hazard. If clothing and household textiles have become badly soiled, they should be rinsed or soaked in water as soon as possible. When power is restored, most items can be machine washed using heavy-duty laundry detergent and warm water.

Insoluble soils may be held onto the fabric by soils, greases or oils by physical attraction. Such insoluble soils require pretreatment using either a laundry cleaning aid or a dry cleaning solvent.

## Cleaning of Pillows, Fabrics, and Textiles

- Brush off surface dirt before washing.
- Soak stained items prior to washing to 'loosen' the stain.
- Pillows: wash in machine or by hand in warm (not hot) suds for 15 to 20 minutes. Use a disinfectant, following product directions for use. If using an automatic washer, wash no more than two (2) pillows or large blankets at one time.
- For large blankets and pillows spin off water or squeeze out as much water as possible.
- Do not use hot water or dry with heat until all stains have been removed. The heat will set the stain.
- Dry using an automatic dryer. Dry pillows with several bath towels to speedup drying. Allow up to 2 hours. Or, air dry pillows on a drying rack or clothes line. Shake and turn pillows and blankets occasionally to fluff feathers and hasten drying.
- Woolen items should be soaked in lukewarm water with mild detergent and disinfectant for 15-20 minutes. Repeat soaking in fresh water if available til clean. Air dry
- Rust remover can be used to remove difficult red or yellow stains. If fabric is not in good condition or is stained with red or yellow mud it may not be possible to remove all objectionable odors and stains.

## **Wet Clothing Textiles**

Wet clothing and household textiles tend to promote mildew and attract insects. Upon returning to your home after urgent clean up items have been tended to, all wet textiles should be hung to dry in a ventilated area. Clean clothing will not mildew as readily as soiled clothing.

Bath towels and kitchen dish cloths should be hung up and allowed to dry between uses.

Remove wall-to-wall tufted carpeting as it readily soaks up water and can contribute to mold and mildew.

## **Treatment of Mildew**

When mildew does occur, the spots should be treated as soon as possible. Any surface growth can be vacuumed or brushed off outdoors to avoid scattering mildew spores in the house. Untreated mildew can weaken fabrics. Mildew-stained articles should be washed with heavy-duty laundry detergent and warm water. The spots can be pretreated with lemon juice or bleach. Articles that are not machine washable may be taken to the dry cleaner.

## **Prevention and Treatment of Insect Infestation on Textiles**

Although insect damage can occur at any time, it is often more of a problem after a hazard event. To prevent insect infestation, carpets and rugs should

be cleaned regularly with a vacuum cleaner. Moving heavy furniture and vacuuming underneath will prevent damage by moth grubs. If the furniture cannot be moved, a residual moth-proof type spray can be applied every six months. It is best to spray the underside and edges of wall-to-wall carpeting before installation. Since upholstered furniture is particularly susceptible to insect damage, the upholstery and underside of the chair or sofa should also be sprayed with a residual type insecticide.

Stored clothing and household textiles should be aired regularly and checked for signs of insect infestation. Before returning items to storage areas, shake, brush, or vacuum to remove insect eggs and other particles. The sudden alteration of temperature kills all stages of clothes moths and house moths. If insect infestation is discovered, if practical, the textile can be placed in a freezer for several days. Immediately after removal, the article should be brushed or vacuumed. If textiles are machine washable, they may be steeped in hot or boiling water to kill the insects. Unfortunately, once the clothing or household textile product is returned to ordinary room temperature, it is liable to become reinfested if a moth alights on it and lays some eggs. The best prevention is good continuous care and storage rotation.

## **Wood Furniture**

Furniture with a natural finish needs only a thorough cleaning to be restored. For a smooth finish, use a furniture cleanser conditioner.

To make a home-made furniture cleanser conditioner, fill a glass container one-fourth full of gum turpentine (not steam distilled) and three-fourths full of commercially prepared boiled laundry bleach. Apply the liquid to a dark spot and let it stand for 15 minutes. Rinse off and repeat, if necessary.

White toothpaste can be used on dark spots if the stain is only a few days old. Water-soaked furniture is likely to warp. Badly warped veneered or press-board furniture is difficult to restore.

## **Books and Walls**

Books, papers and documents should be slowly and carefully dried. Books should be placed upright to dry. Keep pages apart. After exposing each page to the air for a while, place a paper towel between pages and stack books to prevent warping and crumbling. Later, stand the books upright and separate the pages for more drying. This process will prevent mildew.

Water-damaged walls need special care. Plastered walls and wallpaper require different treatments than painted or concrete block walls.

To clean and dry an insulated wall, remove the baseboards and some of the siding to fully ventilate wall cavities. In certain cases, insulation may also need to be removed, dried or replaced. Wait at least two months before applying paint because paint will blister and peel if applied to a wet wall.

Plastered walls and wallpaper can be cleaned without replacing the paper by rinsing with clean water. If the wall paper peels from the wall, let it dry completely before applying glue.

The heavy saltwater content of typhoon rain has a corroding effect on concrete which causes chipping, fragmentation or flaking. If enough clean water is available, rinse the concrete surfaces to give them a longer life. Never use contaminated water for this purpose. For concrete walls, brush loose dirt off dry walls. Wash with mild soap and clean water. Start at the bottom and work up.

## **Old Newspapers and their Usefulness**

If a dry and fire-proof storage space is available in your home, it may be wise to save your daily newspapers. Newspapers, by the nature of their texture, have excellent liquid-absorbing qualities and can be used to clean up water.

Clean-up can be a lot quicker with the use of newspapers. As the sheets on the floors get soaked, simply roll them up and dispose of them. Continue to replace them with fresh, dry sheets as

needed. The use of newspapers can greatly minimize mopping activities. Newspapers make excellent glass/window cleaners. They may also be used to help start outdoor cooking fires.

## HELPING CHILDREN COPE WITH A DISASTER

Natural disasters can destroy the sense of balance children have. In addition to restoring buildings and replacing material possessions, victims may need to restore their own emotional equilibrium.

This can be especially important for children who do not have years of life experience to guide them. Be extra patient. Keep in mind that what your spouse or partner considers a top priority may be different from your priorities. Don't expect things to instantly restore themselves. Restoration, both physical and emotional, takes time. Realize that hazard victims have suffered losses and that it is natural for them to express disbelief, anger, sadness, anxiety or depression. Realize that the emotions and moods of victims will change unexpectedly. Don't overlook children's feelings. They need to feel they can

count on you for extra attention, love and support. Reassure them. Make sure they understand that they are not responsible for the problems you face. Try to keep your family's diet nourishing. Talk with friends, family and your parish priest or minister. In a crisis situation, a support network is essential.

Be aware of the tendency to resort to bad habits when you are under stress. It is normal for children to be afraid. Their fear may last for an extended period of time and is best handled by kindness and understanding. Encourage children to talk about their feelings and express their fears through play, drawing, painting and/or clay.

Children's fears vary according to age, maturity and previous experiences. Four common fears are death, darkness, animals and abandonment. Children's fears may be intensified when adults back away from discussing certain topics with them. To help children cope with fears, it's important for adults to allot time to talk with children.

**Following a hazard, some children may:**

- Be upset at the loss of a favorite toy, blanket, teddy bear, etc.
- Be angry. They may hit, throw or kick things to show their anger.
- Become more active and restless.
- Be afraid of a recurrence of the hazard. They may ask questions such as, "Will it come again?"
- Be afraid to be left alone or sleep alone. They may have nightmares.
- Behave as they did when younger. They may start sucking their thumb, wetting the bed, asking for a bottle or wanting to be held
- Show symptoms of illness such as nausea, vomiting, headaches, fever, or loss of appetite.
- Be quiet and withdrawn, not wanting to talk about the experience.
- Become easily upset, crying, and whining frequently.
- Feel guilty that they may have caused the disaster because of some previous behavior.
- Feel neglected by parents who are busy cleaning and rebuilding their lives or homes.
- Refuse to go to school or to child-care arrangements. The child may not want to be out of the parent's sight.
- Become afraid of loud noises or hazard related sounds.
- Not show any outward signs or being upset. Some children may never show distress because they do not feel upset. Other children may not

give evidence of being upset until several weeks or months later.

**What Parents and Other Adults Can Do:**

- Let children know you love them and that they can count on you. Reassure them and that they are not responsible for the typhoon.
- Talk with your child and provide simple and accurate information to questions.
- Talk with your child about your own feelings.
- Listen to what your child says and how your child says it. Is there fear, anxiety or insecurity? Repeating the child's words such as, "You are afraid that," or "You wonder if the storm will come again tonight," helps both you and the child clarify feelings.
- Reassure your child by saying, "We are together. We care about you. We will take care of you."
- You may need to repeat information and reassurances several times. Do not stop responding just because you spoke to the child once or even 10 times.
- Hold your child. Touching is important. Close contact helps assure children that you are there for them and will not abandon them.
- Spend extra time putting your child to bed. Talk and offer assurances.
- Observe your child at play. Listen to what is said and how the child plays. Frequently, children express feelings

of fear or anger while playing.

- Provide some play experiences to relieve tension. Work with clay, paint, play in (clean) water, etc. Allow a safe and open space for them to play, if possible.
- If your child lost a meaningful toy or blanket allow the child to mourn and grieve. It is all part of helping the child cope with feelings about the disaster. In time, it may be helpful to replace the lost object.
- If you need help for your child, contact a community resource such as Guam Department of Public Health and Human Services or a ministry.





# NOTES

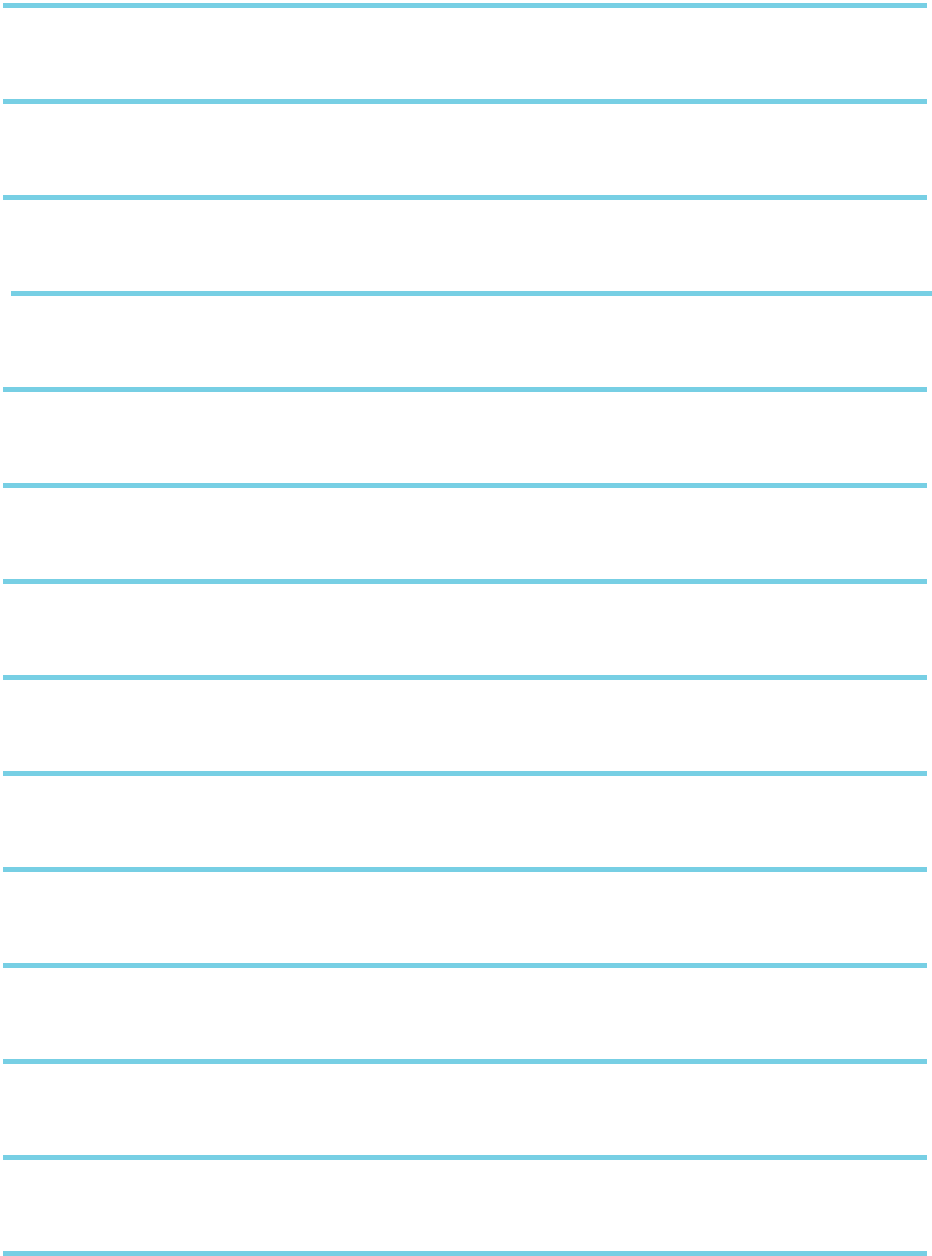

A series of 18 horizontal blue lines for writing notes. On the left side of the page, there is a blue rounded rectangle that partially overlaps the lines.

# CHECKLISTS AND TOOLS

## REFERENCE GUIDE

Family Emergency Plan .....	119
Important Contact Information.....	120
Shelter Information.....	122
Emergency Kit Checklist .....	123
COR 3 & 2 Preparation Checklist (Home, Yard, Vehicles).....	124
COR1 Preparation Checklist .....	126
Hazard Recovery Checklist.....	127
Food & Water Safety Checklist .....	128
Hazardous Materials Information .....	129
Notes.....	130

# Family Emergency Plan

<p><b>Family members</b> <i>(List everyone living in your home)</i></p>	<p><b>Name:</b> _____ <b>Date of Birth:</b> _____  <b>Social Security #</b> _____ <b>Phone:</b> _____</p> <p><b>Name:</b> _____ <b>Date of Birth:</b> _____  <b>Social Security #</b> _____ <b>Phone:</b> _____</p> <p><b>Name:</b> _____ <b>Date of Birth:</b> _____  <b>Social Security #</b> _____ <b>Phone:</b> _____</p> <p><b>Name:</b> _____ <b>Date of Birth:</b> _____  <b>Social Security #</b> _____ <b>Phone:</b> _____</p> <p><b>Name:</b> _____ <b>Date of Birth:</b> _____  <b>Social Security #</b> _____ <b>Phone:</b> _____</p>
<p><b>Other important phone numbers</b></p>	<p>Off island family: _____          Family doctor: _____          Pharmacist: _____          Medical insurance: _____</p>
<p><b>Where is everyone during the day and where do we meet if there is an emergency?</b></p>	<p><b>Work #1:</b> _____ <b>Village:</b> _____  <b>Phone:</b> _____ <b>Evacuation location:</b> _____</p> <p><b>Work #2:</b> _____ <b>Village:</b> _____  <b>Phone:</b> _____ <b>Evacuation location:</b> _____</p> <p><b>Work #3:</b> _____ <b>Village:</b> _____  <b>Phone:</b> _____ <b>Evacuation location:</b> _____</p> <p><b>School #1:</b> _____ <b>Village:</b> _____  <b>Phone:</b> _____ <b>Evacuation location:</b> _____</p> <p><b>School #2:</b> _____ <b>Village:</b> _____  <b>Phone:</b> _____ <b>Evacuation location:</b> _____</p> <p><b>School #3:</b> _____ <b>Village:</b> _____  <b>Phone:</b> _____ <b>Evacuation location:</b> _____</p> <p><b>Other #1:</b> _____ <b>Village:</b> _____  <b>Phone:</b> _____ <b>Evacuation location:</b> _____</p> <p><b>Other #2:</b> _____ <b>Village:</b> _____  <b>Phone:</b> _____ <b>Evacuation location:</b> _____</p>

## Important Contact Information & Phone Numbers

**Table 3.2. Primary Radio and TV Stations**  
 These stations have partnered with the Joint Information Center to distribute information about hazards to the region.

<b>Radio Stations</b>	
<b>Guam</b>	<b>CNMI</b>
570 AM - Newstalk57	1440 AM - KKMP
610 AM - Isla63	99.5 FM - KZGU
93.9 FM - I94	100.3 FM - KWAU
95.5 FM - KStereo	103.9 FM - KZMI
98.7 FM - Power 98	
101.9 FM	
105.1 FM - The Kat	
<b>TV Stations</b>	
8 & 11 - KUAM-TV (NBC)	<a href="http://www.kuam.com">www.kuam.com</a>
7 - KGTM-TV (ABC)	<a href="http://www.pacificnewscenter.com">www.pacificnewscenter.com</a>
See Emergency Alert System (EAS) announcements on cable stations.	

**Table 3.3. Agency Contact Information - Guam and CNMI**

Agency	Website	Phone
NOAA National Weather Service	<a href="http://prh.noaa.gov/guam">prh.noaa.gov/guam</a> or <a href="http://www.weather.gov/guam">www.weather.gov/guam</a>	671.472.0900
Guam Homeland Security/Office of Civil Defense (Joint Information Center)	<a href="http://www.guamhs.org">www.guamhs.org</a>	671.475.9600
CNMI Homeland Security and Emergency Management	<a href="http://www.cnmihsem.gov.mp/">www.cnmihsem.gov.mp/</a>	670.237.8000
Office of the Governor and Lt. Governor, CNMI	<a href="http://www.cnmihsem.gov.mp/">http://www.cnmihsem.gov.mp/</a>	670.664.4550/445
U.S. Geological Survey (earthquakes)	<a href="http://geomag.usgs.gov/observatories/guam">geomag.usgs.gov/observatories/guam</a>	804.261.2600
U.S. Geological Survey (volcanoes)	<a href="http://volcanoes.usgs.gov/nmi/activity/index.php">volcanoes.usgs.gov/nmi/activity/index.php</a>	804.261.2600
Guam Power Authority	<a href="http://www.guampowerauthority.com">www.guampowerauthority.com</a>	671.475.1568
Guam Waterworks Authority	<a href="http://guamwaterworks.org">http://guamwaterworks.org</a>	671.647.7800
Guam Fire Department	<a href="http://www.gfd.guam.gov">www.gfd.guam.gov</a>	671.642.3534 or 911
Guam Police Department	<a href="http://gpd.guam.gov">gpd.guam.gov</a>	671.475.8489
Department of Public Health and Social Services	<a href="http://www.dphss.guam.gov">www.dphss.guam.gov</a>	671.735-7128/7104
Department of Agriculture /Aquatic and Wildlife Resources Territorial Veterinarian	<a href="http://doag.guam.gov">doag.guam.gov</a>	671.735.3942
American Red Cross	<a href="http://www.redcross.com">www.redcross.com</a> or <a href="http://www.redcross.com/gu/hagatna">www.redcross.com/gu/hagatna</a>	671.472.6217 or 670.234.3457
Guam Memorial Hospital	<a href="http://gmha.org">gmha.org</a>	671.647-2555 - 9
Guam Regional Medical City	<a href="http://www.grmc.gu">www.grmc.gu</a>	671.645.5500
FEMA	<a href="http://www.fema.gov">www.fema.gov</a>	1-800.621.3362

## Mayor/Shelter Contact Information

Village	Phone Number
Agana Heights	472.6393/8285/6
Agat	565.2524/31
Asan-Maina	472.6581; 479.2726
Barrigada	734.3724
Chalan Pago/Ordot	472.8302/7173
Dededo	632.5203/5019; 637.9014
Hagatna	477.8045; 472.6379
Inahalan	475.2509-11
Mangilao	734.2163/5731; 734.5734/5
Merizo	828.8312/2941
Mongmong-Toto-Maite	477.6758/9090; 479.6800/1
Piti	472.1232/3
Santa Rita	565.2514/4337/4302/4
Sinajana	472.6707; 477.3323/9229
Talofofo	789.1421/3262/4821
Tamuning-Tumon	646.5211/8646; 647.9816/19/20
Umatac	828.2940/8258
Yigo	653.5248/9446/9119; 633.3001/2/3/5
Yona	789.4798/1525/6

## Pet Boarding Facilities

Veterinary Clinic/Boarding Facilities	Phone Number
Cloud 9 Kennel	637.5881
Isla Veterinary Clinic	477.7879
Boonie B&B	989.3647
Marianas VetCare	734.6341
American Medical Clinic	637.8387
Wise Owl Animal Hospital	646.2273/456.3029

## Table 3.1. Emergency Kit Checklist

- Two (2) copies of your family emergency plan (see page 119)
- Personal ID for all
- Cash for purchasing incidentals
- Extra copies of insurance papers, list of prescriptions, and family health records
- First aid kit and manual prescription and nonprescription medicines for at least 7 days
- Extra pair of glasses/contact lenses
- Three (3) gallons of water per person
- Seven (7) day supply of non-perishable foods
- Manual can opener
- Flashlight and extra batteries
- Candles and matches
- Multi-tool or wrench/pliers
- Personal hygiene items
- One (1) comfort item per child
- Pet supplies

### Additional Items to Consider:

- Whistle to signal for help
- Spare set of car and house keys
- Paper cups and plates and plastic utensils
- Portable gas stove with cans of fuel
- Blankets or sleeping bags
- Baby wipes and/or hand sanitizer
- Plastic trash bags
- Change of clothes and rain gear
- Sunscreen and insect repellent
- Additional play items for children
- Special items for infants
- NOAA Hand-crank Weather Radio

NOTE: FEMA recommends a three (3)-day supply of food and water, however, because of the Marianas geographic isolation it is recommended to prepare for at least seven (7) days.



## Table 3.4. COR 3 & 2 Emergency Preparation Checklist

### Home

- Have enough canned or dried food for seven days.
- Fill as many buckets, bathtub and trash cans with water as possible.
- Double-check your emergency kit.
- Put up or close shutters or other wind resistive device.
- Secure or move inside all items that might become airborne and hit your house, car or neighbors.
- Tie bikes, play equipment and lawn furniture together with rope, under the carport, to a brick wall.
- Take down canopies and poles.
- Get charcoal and propane for grills.
- Get candles and matches or lighters.
- Get medicines and prescriptions organized.
- Get the generator ready for use. Have extra fuel on hand (see page 86).
- Store clothes, blankets and pillows in plastic bags. Cover beds with plastic sheeting.
- Put sandbags under the entrances to the house where water could leak in.
- Do all the laundry.
- Raise valuable items 1-18 inches off of the ground because of possible flooding.
- Put all essential appliances and electronics on surge protectors.
- Set refrigerator and freezer to coldest setting and pack freezer with water.
- Unplug appliances you are not using to prevent damage from power outages or fluctuations.
- Remove or waterproof window air conditioners.
- Help children prepare mentally for a natural disaster.
- Avoid exiting shelter during temporary “calm” of storm’s eye.
- Don’t use generators until COR 4 has been declared after the storm.
- Call 911 for life threatening emergencies.
- After the winds have passed remain inside until the ALL CLEAR is given.
- Conserve water. It is possible that water service may be limited for several days or weeks.
- Fill containers with water.
- Recheck manufactured home tie-downs.
- When the power goes off, turn off your main breaker. This can prevent fire.
- Secure boats.
- Crack a window on the leeward side of the structure to equalize the pressure inside the structure.
- Remove trampoline safety nets, center jumping area and put them inside. Flip pipe structure upside down.

## Table 3.4 Emergency Preparation Checklist (con't.)

### Vehicles

- Fill vehicles with gas.
- Remove any valuable items from your vehicles.

- Park your car on high ground next to a concrete wall or on a side of the house that is protected from the wind.

### Yard and Ranch

- Secure or move inside all items that might become airborne and hit your house, car or neighbors.
- Store animal feed to last at least 5 days. Wrap feed in heavy-duty plastic to keep dry. Molds and fungi easily grow on wet feed and can render it useless.
- Avoid any form of stress to the animals before and after a hazard including transporting, handling, and moving animals repeatedly.
- Postpone any forms of husbandry practices such as castrations, weaning, ear notching, debeaking and vaccinations.
- Treat drinking water for poultry with soluble antibiotics and electrolytes two days before and three days after an event. Follow appropriate withdrawal periods.
- Move livestock and poultry to a covered facility with a secure roof if possible. Young animals are likely to die when exposed to cold conditions brought by wind and rain.
- Secure any loose materials to prevent banging noises, which may further irritate the animals.

- Move all equipment indoors.
- Raise valuable items 1-18 inches off of the ground to prevent damage from flood waters.
- If substantial storm damage is anticipated, you can begin new plantings before the storm hits. If a safe area is available, seeds can be germinated in seedling trays.
- Harvest all mature vegetables & fruits and those that can be used in their green or unripe stage.
- Eggplants and peppers can be pruned to 2-4 branches and to about 1-1½ feet in height.
- If practical, lay trellised crops on the ground.
- If flooding is a concern, provide an avenue for water to drain out of the field. Avoid diverting water into the neighbor's yard or other property of significant use.
- Prune banana and papaya plants by cutting all but the three youngest, healthy leaves; cut these three leaves in half lengthwise and leave the smaller top leaves and growing tip uncut.

## Table 3.5 COR 1 Emergency Preparation Checklist

### Home

- 12 hours before landfall.
- Stay calm. **STAY INDOORS.**
- Do not go out on the roads. Only emergency vehicles are allowed to drive.
- Evacuate if you are asked to do so.
- If you are not advised to evacuate, stay indoors and away from windows.
- Place rags or towels around the bottom of doors and windows.
- Listen for updates from the NOAA Weather Office on radio, television and online. See the full list on page 77.
- Listen to directions given by local officials over radio and in the newspaper.
- Be prepared to evacuate, especially if you live in a non concrete home.
- Bring animals inside. Turn off main breaker for power and main line for water if told to do so.
- Keep refrigerator at coldest setting.
- Keep refrigerator doors closed.
- Turn propane tanks off.
- Avoid using the phone except in emergencies.
- Be aware of the calm "eye;" the storm is not over. The worst part of the storm will happen when the eye passes over and the wind comes from the opposite direction.
- Move family into a small room in the center of the building.
- Closets or hallways on the lowest level are the best choice.

## Table 5.1. Hazard Recovery Checklist

After the emergency is over, call or text your family and friends to tell them you are safe.

Take photos of the damage and necessary repairs for insurance purposes.

### **If you must walk or drive in areas that have been affected:**

- Stay on firm ground. Moving water only six (6) inches deep can sweep you off your feet. Standing water may be electrically charged from underground or downed power lines.
- Identify downed power lines and do not touch them.
- Use extreme caution when entering or working in buildings - structures may have been damaged or weakened.
- Inspect your home and property for damage. Do not go in your home if it appears to have significant structural damage.
- Wear sturdy shoes when walking through broken glass or debris, and use heavy gloves when removing debris.

### **Check gas, water and electrical lines and appliances for damage.**

- Use a flashlight to inspect for damage.
- If main gas lines or electrical switches were not turned off prior to the hazard, turn them off until you have checked the structure to ensure there are no broken gas lines or electrical hazards. Have these services restored by a professional.
- Report any damage to water supply, sewer facilities, embankments, or roads by contacting the water company or your mayor.
- Notify the power or fire authorities on your island if you see fallen or damaged electrical wires.
- If any of your appliances are wet, turn off the main electrical power switch in your home before you unplug them. Dry out appliances, wall switches and sockets before you plug them in again.

### **If you smell leaking gas, turn off the main valve.**

- Do not use candles, lanterns, electrical or torches of any kind as they can cause an explosion if there is gas in the air.
- Ventilate the structure before lighting any matches or candles.

## Table 5.2. Drinking Water Safety Checklist

### DO

- Listen for all public announcements about water.
- The water company will announce when and if the tap water is safe to drink and use.
- If the tap water is not safe, follow instructions on boiling the water to disinfect it for cooking, cleaning and bathing.
- Only use bottled water from a safe source. If you don't know where it came from, boil it before use. If you can't boil the water, use chlorine tablets, iodine tablets or chlorine bleach. Follow the directions for each. Using these methods will not kill all parasitic organisms.

### DO NOT

- Drink the water until you are told it is safe to do so.
- Drink cloudy water or water with an unusual odor.
- Drink water labeled as non-potable
- Use water disinfection methods that have not been recommended by GWA.

## Table 5.3 Food Safety Checklist

### DO

- Throw away food that may have come in contact with flood or storm water.
- Throw away food that smells odd, looks odd, or has an odd texture.
- Throw away perishable foods (meat, poultry, fish, eggs and leftovers) that have been 40°F for two hours or more.
- Throw away canned food that is bulging opened or damaged.
- Throw away any food in a sealed jar or container that may have come into contact with floodwater. These items can't be disinfected.
- Rinse any canned food item in bleach. Remember to take labels off because they may have dangerous bacteria.

### DO NOT

- Keep or eat anything that has touched flood waters.
- Keep any perishable food that has been sitting out for longer than 2 hours.
- Throw away food that is still frozen, unless it has touched flood water.
- Use contaminated water to wash dishes, brush your teeth wash, prepare food, wash your hands, make ice or baby formula.

## Table 5.4 Potential Hazardous Materials

Hazardous Item	Toxic	Flammable	Explosive (in fire)	Reactive
Paints	✘			
Adhesives	✘	✘		
Paint Thinner	✘	✘		
Pesticides	✘	✘		
Fertilizers	✘	✘ (most)	✘ (if mixed with gasoline)	✘
Gun Ammunition			✘	
Aerosols			✘	
Natural Gas		✘	✘	
Sewer Gases (from broken pipes)	✘		✘	
Alcohol		✘		
Nail Polish Remover		✘		
Gasoline	✘	✘		
Brake Fluid	✘	✘		
Antifreeze	✘	✘		
Oil		✘		
Transmission Fluid	✘	✘		
Cleanders				✘
Cooking Oil		✘		
Detergents				✘



